

Datatech Bluethink Data PFW

70÷260 kW



General

Air conditioners specifically designed for IT applications: maximisation of sensible capacity, efficiency, reliability, availability and redundancy. They additionally provide for utmost flexibility in terms of direction of the air delivery lines for better adaptation to the different layouts of the various sites.

The design featuring a separate fan section is intended for maximised aerodynamic efficiency through the optimisation of the coil spaces and the EC fan operating mode.

Configurations

PFW: Direct expansion air conditioning unit with single circuit.

PFW /DW: Direct expansion air conditioning units air cooled, with DC-Inverter scroll compressor.

Strengths

- ▶ High sensible cooling per footprint square metre
- ▶ Ad hoc solution conceived for applications with maximised free cooling (HE coil)
- ▶ Full accessibility (solutions to increase fan accessibility when installed underneath the floor, etc.)
- ▶ Total connectivity
- ▶ Easy and flexible installation (solutions designed for quicker connection of the 2 sections, etc.)
- ▶ Full redundancy hydraulic option for data centres Tier IV (version DW)

WESTERNTM
AIRCONDITIONING
WARMTEPOMPEN

BlueBox 
by Swegon

FRAMES AND DIMENSIONS	3
AIR FLOWS	3
DATATECH BTD PFW	4
APPLICATIONS	4
CONFIGURATION	7
SPECIFICATIONS	7
DESCRIPTION OF ACCESSORIES	12
TECHNICAL SPECIFICATIONS	35
Datatech BTD PFW - Chilled water version	35
Datatech BTD PFW DW - Dual circuit chilled water version	36
TECHNICAL SPECIFICATIONS	37
HYDRAULIC DIAGRAMS	38
OPERATING LIMITS - DATATECH BTD CW-DW	39
INSTALLATION TIPS	40



FRAMES AND DIMENSIONS

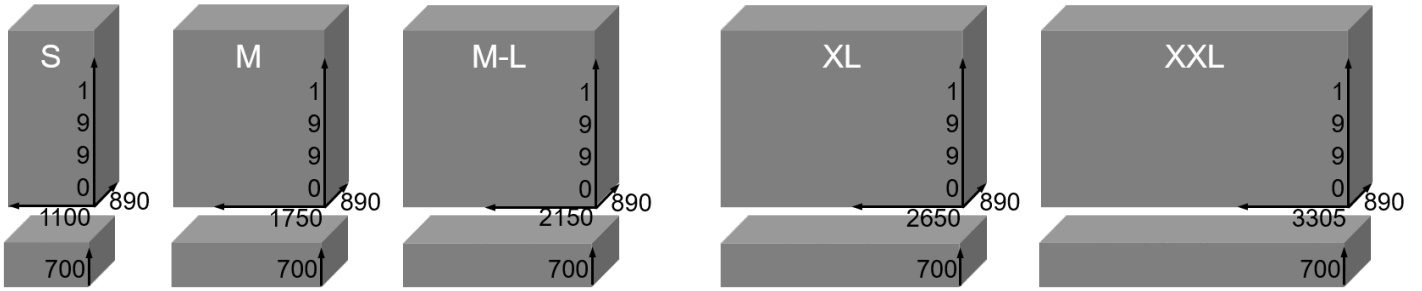

AIR FLOWS

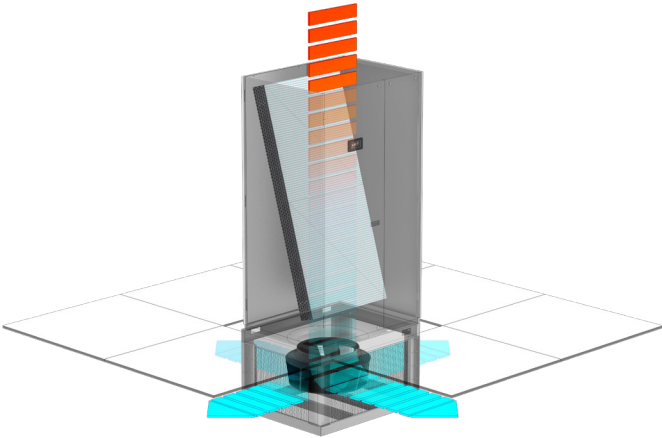

ASPS: Downflow delivery, Underfloor fans with fully open fan section

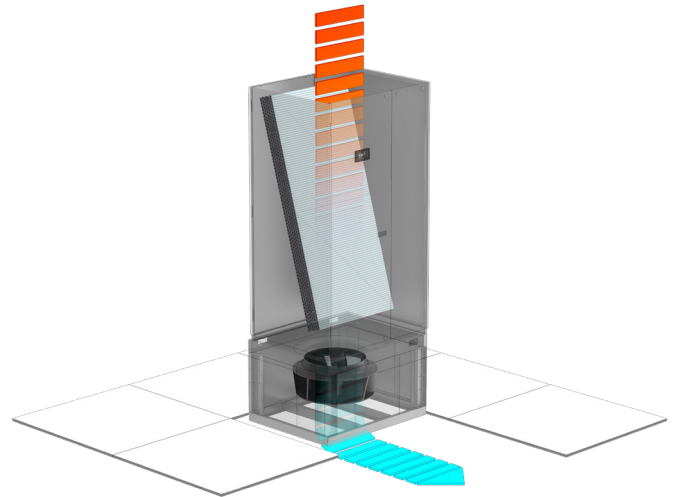

CSPS: Downflow delivery, Overfloor fans with fully closed fan section on the side

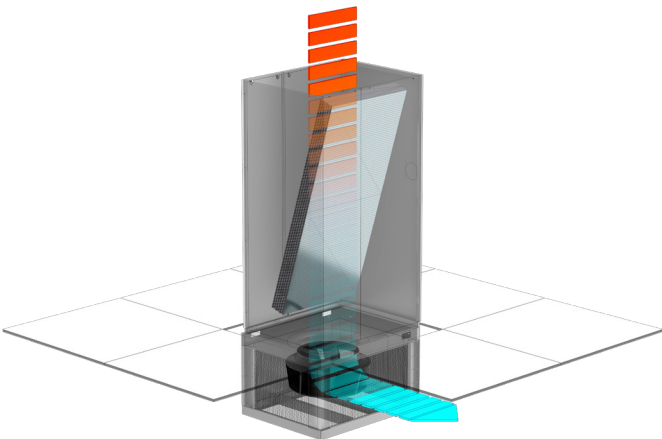

EOCC: Back delivery, Underfloor fans with open fan section at the back

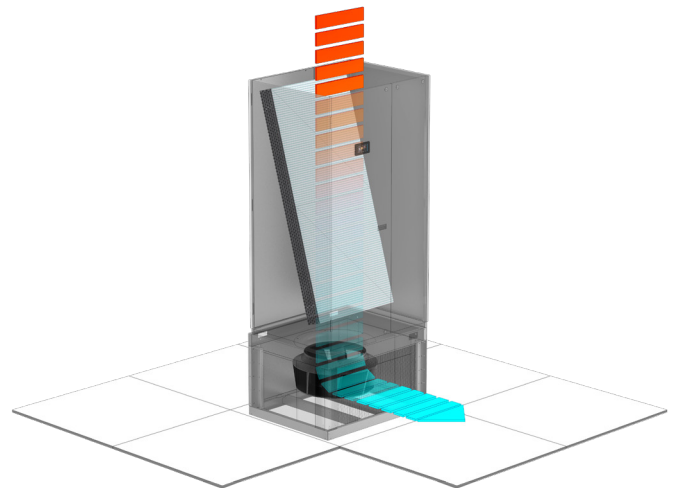

EOGA: Front delivery, Overfloor fans with open fan section at the front with grid

DATATECH BTD PFW

Datatech BTD BT is the solution for all technological applications requiring optimised and continuous monitoring of the thermo-hygrometric conditions in which the various apparatuses operate.

Datatech BT is a series of vertical air-conditioning cabinets which are available in different versions and set-ups for better adaptation to the various systems.

Air conditioning units are available in single-circuit chilled water versions or dual-coil chilled water (dual water) version. The offer is completed by an extensive range of aerualic, hydraulic and electrical options to be fitted on the Datech units to increase the product customisation options and make it the most suitable solution to meet the diversified needs of its users.

APPLICATIONS

Datatech BT units are mainly used as air-conditioning solutions for IT equipment. This specific application context has direct repercussions on the machine design in that machines are optimised to meet the relevant requirements. Below is a short introduction to the main distinguishing design features of IT air-conditioning units. A more in-depth description is then provided in the following sections.

- **Extended indoor work conditions** The ASHRAE guidelines (American Society of Heating Refrigeration Air-conditioning Engineers) are globally recognised as the standards for the monitoring of environmental conditions in Data Centres. The above-mentioned conditions have been extended over the years and they require that all air-conditioning units can operate with increasingly higher input air temperatures.
- **Optimisation of sensible capacity** IT equipment represent a purely sensible load. As a result, Datatech BT units have thermodynamic and aerualic parameters specifically designed for max. sensible capacity under design conditions as opposed to latent capacity.
- **Maximum service continuity** The IT load, by its very nature, is present uniformly all year round. Air-conditioners used for these applications must take into account the ultimate target consisting in the provision of continuous operation throughout the year. As is the case with the operating conditions, service continuity too is defined by specific guidelines which are laid down by a private entity known as UPTIME INSTITUTE.

Ashrae and guidelines for optimised thermo-hygrometric conditions in data centre applications

ASHRAE Technical Committee 9.9, which is named "Mission Critical Facilities, Technology Spaces and Electronic Equipment", offers a wide range of information for the IT sector. The first publication of TC 9.9 "Thermal Guidelines for Data Processing Environments" addresses some critical issues, including the operating temperature, humidity, the air flow through the equipment and the points of measurement of the environmental conditions.



It specifically defines temperature and humidity limits which are deemed as optimised or acceptable for these applications. These limits include:

- recommended limits (ASHRAE Recommended Envelope) – conditions within which IT equipment (e.g. servers, etc.) operate in conditions of optimal balance between operating costs and long-term reliability;
- allowable limits (ASHRAE Allowable Envelope A1-A2-A3-A4) – less stringent conditions within which it is tolerable for equipment to operate for shorts operating periods.

Below is an illustration that shows the work areas as defined in the latest publication.

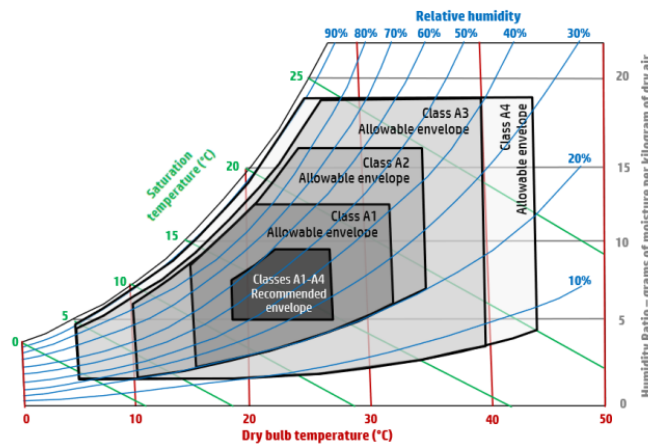

Note: Envelopes define air entering IT equipment operating at sea level.

It is now important to stress that the conditions illustrated in the ASHRAE diagram refer to air in front of racks/servers, in other words air available for equipment cooling. In modern Data Centres, for instance, configurations are such as to keep the air delivery flows to the equipment separate from the air return flows to the air-conditioners for maximised efficiency.

Sensible capacity vs. Latent capacity

The key parameter to measure the quantity of sensible heat removed as opposed to latent heat is the sensible heat ratio, otherwise known with the acronym SHR. This is the ratio (in congruent units of measurement, for instance [kW]) between the sensible capacity and the total capacity.

It is quite easy to identify the sensible capacity and the latent capacity along the air treatment line in a psychrometric chart.

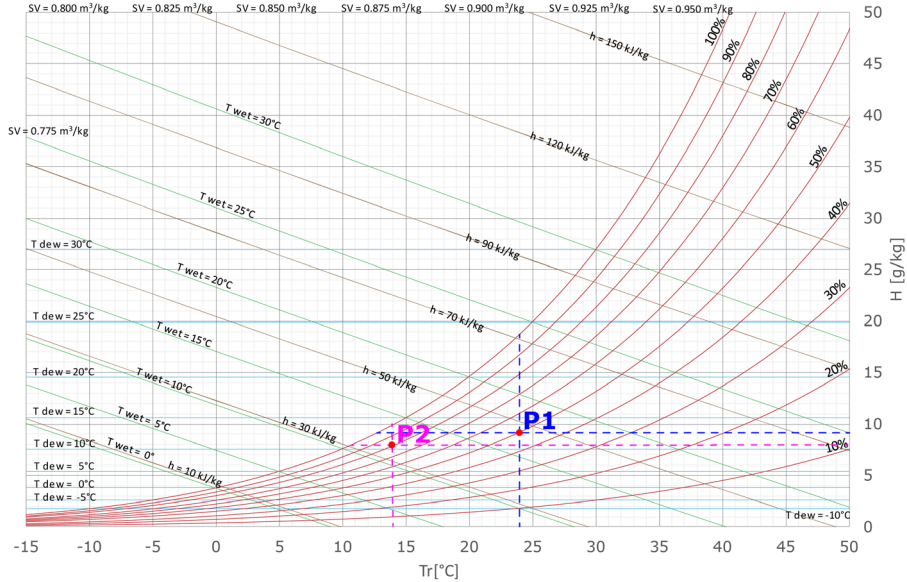

Sensible capacity corresponds to the pure temperature drop, as shown in the figure, to reduce the temperature from 24°C to 14°C. Latent capacity, on the other hand, corresponds to the shift of the water vapour to condensate, which changes the humidity content from 9.3g/kg to 8g/kg (i.e. the amount of water removed is 1.3g per kg of dry treated air).

Needless to say, latent capacity in applications mainly requiring sensible capacity is not useful and actually causes water condensation, which consequently reduces the relative humidity. This may not be acceptable and results in the usage of electricity and water to humidify the environment again.

Uptime and guidelines for service continuity maximisation

The Uptime Institute has created a Tier Classification System standard, i.e. a tool which is used for efficient evaluation of the data centre infrastructure in terms of company requirements for system availability. The Tier Classification System provides the Data Centre sector a consistent method to compare customised facilities (generally, unique) according to the performances of the site infrastructure contemplated by Uptime.



The "Data Centre Site Infrastructure Tier Standard: Topology" outlines the requirements and benefits resulting from four Tier classifications, as identified for the Data Centre infrastructure. Each Tier is aligned with a specific function in the business world and sets appropriate criteria for power supply, cooling, maintenance and the system ability to resist to a fault. Tiers are progressive: each tier incorporates the requirements of all underlying tiers.

TIER	Definition	Redundancy	Description	Service disruption accepted
1	Basic site infrastructure	Non-redundant capacity components, non-redundant distribution path	The site is susceptible to disruption from both planned and unplanned activities/events. An outage or failure of any capacity component will have an impact on the critical environment.	99,671% 28,819hours/year
2	Redundant site infrastructure	Redundant capacity components, non-redundant distribution path	The site is susceptible to disruption from both planned and unplanned activities/events. A component error may have an impact on the critical environment. An outage will have an impact on the critical environment.	99,741% 22,670hours/year
3	Site infrastructure allowing for simultaneous maintenance	Redundant capacity components, redundant distribution path (main and backup)	The site is susceptible to disruption from unplanned activities/events. Scheduled maintenance has no impact.	99,982% 1,5770hours/year
4	Fault tolerant site infrastructure	Redundant capacity components, independent redundant distribution paths (both active)	The site is not susceptible to disruptions from one single unplanned event or scheduled maintenance.	99,995% 0,440hours/year

Datatech BTM units offer set-ups, options and software solutions that have been conceived to meet this type of need at best.

CONFIGURATION

Configuration example:

Datatech	PFW	70	DW
1	2	3	4
1	Series	Datatech	
2	Air flow	PFW : Air downflow with separate and configurable fan section	
3	Size	xx : Nominal cooling capacity at catalogue conditions	
4	Version	-- : Chilled water (single circuit) DW : Chilled water (dual circuit)	

SPECIFICATIONS

STRUCTURE

Datatech PFW units are structurally divided into two sections: an air cooling and handling section, and a fan section.

Description of cooling section:

For enhanced thermal and acoustic insulation the units consist of a load-bearing frame made of a 22 mm thick sandwich sheet metal, with internal insulating glass wool material, 30 kg/m³ density. The fire reaction class of the panelling is A1 (in accordance with EN13501). Air tightness is achieved with adhesive sealing strips placed all around the edges of the panels.



The internal sheet metal parts are hot galvanised and have variable thickness (from 2.5 mm for the base to 1 mm for removable panels), whereas visible parts are painted with an oven-baked epoxy polyester powder coating RAL7016 and have a textured surface finish.

The frame is secured with structural rivets. The front and rear panels are fixed with ¼ turn fasteners or they are screwed to the top part, respectively, and they are supplied with tabs for installation in dedicated slots on the base. The front panel opposite the electric switch is hinged and supplied with a handle for opening.

Access to all the main components of the unit is gained from the front, so no clearance spaces must be left at the sides and back of the unit for both routine and non-routine maintenance.

Description of fan section:

These two sections are always shipped separately and they are finally assembled to the installation through both mechanical and electrical connections. Quick connectors are used for electrical connection. A seal is supplied separately from the unit to be fitted between the two sections. The fan section is made of a galvanized sheet metal frame and it is painted with an oven-baked epoxy polyester powder coating RAL7016. It hosts the fans and the post-heating electric heaters. The version intended for underfloor installation includes an accident-prevention safety grid and a perimeter bracket to support the raised floor. Versions for overfloor installation are enclosed with double skin panels that have the same features as the panels in the air handling section and a larger horizontal ejection grid or a flange for connection to the channel.

All the materials making up the unit are CFC-free.

As standard, the hydraulic connections are made on the bottom right-hand side in single-circuit units and on both the bottom right- and left-hand side in dual-circuit units. Different solutions are available as options for connection in different positions.

On the air side, the units are supplied with four threaded hex inserts M6 that are designed to connect the return/delivery plenum or to fit the ducting in the unit, where required.

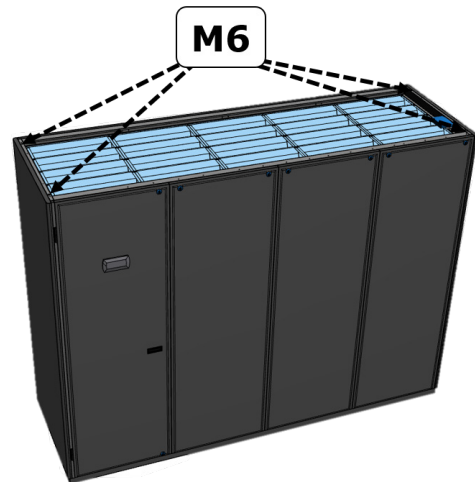

FANS

Units are equipped with 1, 2, 3 and/or 4 radial fans with backward-curved blades, without scroll. Fans are balanced, as required by standard ISO DIN 1940. The fan impeller is made with composite material with 3D profile.

Units are fitted with a three-phase, 400V/50Hz motor.

The average air capacity value is 82 l/s per kW of sensible cooling capacity.

Fans are fitted with brushless, electronically commutated (EC) motors and they offer a number of advantages.

- greater efficiency at full load if compared with the corresponding AC model;
- Cosφ value close to 1;
- built-in soft starter;

- user-friendly adjustment - the 0-10V control signal enables monitoring the motor speed electronically with continuous regulation via the microprocessor onboard the unit so as to implement various control strategies (constant flow, constant pressure, based on thermal load, etc.).
- The motors are provided with integrated electronic protection against overtemperature, overcurrent, over or under-voltage with absence of one or more phases.

The strategic advantage of EC fans is the cubic ratio between speed and absorption. In other words, the consumption of a fan running at 70% is 50%, it is 18% when running at 50%, etc.

This brings about a potential saving that is exponential to partial loads. Hence, the need exists to modulate the fan efficiently and continuously using the correct algorithm required by the application.

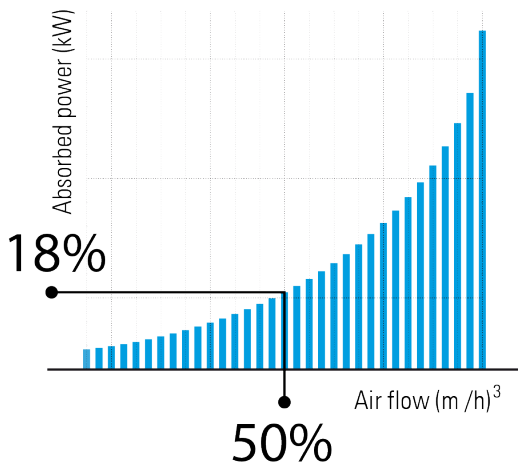

Technical specifications of EC fans

EC FANS WITH COMPOSITE IMPELLER							
Cabinet		S	S-M	M	M-L	XL	XXL
Nominal diameter	mm	630	500	560		630	
No. fans		1	2		3	4	
Max. speed	rpm	1300	1700	1650	1300		
Max. power absorbed by each fan	kW	2.75	2.70	2.90	2.75		
No. phases		3					
Power supply	V	380 - 480					
Frequency	Hz	50 - 60					
Protection level		IP 54					
Insulation class		F					

Fans are fitted with an air flow sensor that warns about missing air and a thermal overload protection.

AIR FILTERS

The filters are pleated and in a rigid galvanized steel frame, filtration class ISO Coarse 75% (ISO 16890-3; G4 - EN779), and designed to minimize head losses and to have a high degree of filtration. The thickness of the filters can be 50 or 100 mm depending on the sizes or the set-ups. The filters are always removed from the front of the unit. Higher efficiency and low head loss filters ISO ePM10 (M5), ISO ePM10 75% (M6), ISO ePM1 50% (F7) may be supplied upon request (refer to the corresponding options for further details).



If the specific option (CF) is ordered, the condition of the filters is constantly monitored by a differential pressure switch that signals when they are excessively fouled.

HYDRAULIC CIRCUIT

The hydraulic circuit comprises:

- Single- (CW) or interlaced dual-circuit (DW) water-chilled coil
- threaded hydraulic connectors; (two separate hydraulic connections for DW units, one for each interlocked coil)
- a 3-way chilled water valve with modulating servo control. (two valves for DW units, one for each circuit)

The chilled water circuit is PN10.

CHILLED WATER VALVE

Chilled water valves are brass body, ball valves with equal percentage flow on the straight line and linear flow on the bypass line, including threaded female connectors. These valves are supplied with a modulating, microprocessor-controlled servo onboard the machine with 0-10V signal.

Technical specifications (for single-circuit units)

Model	Kvs (straight line)	Kvs (Bypass line)	max. differential pressure [kPa]
70	25	16	240
90	25	16	240
120	40	25	240
150	40	25	240
200	63	31.5	240
260	63	31.5	240

Technical specifications (for dual-circuit units)

Model	Kvs (straight line)	Kvs (Bypass line)	max. differential pressure [kPa]
70	16	10	240
90	25	16	240
120	25	16	240
150	40	25	240
200	40	25	240
260	63	31.5	240

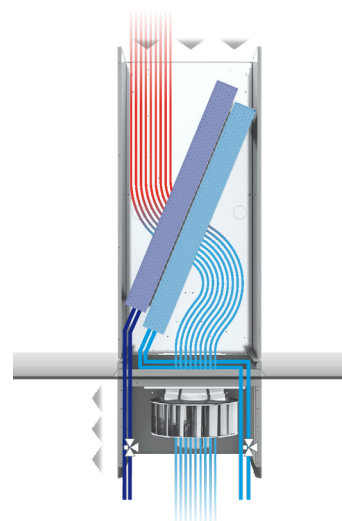

WATER COILS

Coils are finned pack type and they consist of copper tubes and aluminium fins with corrugated profile and hydrophilic surface treatment.

All chilled water coils are supplied with an air exhaust valve and a threaded drain plug, and they are guaranteed for pressures up to 16 bar.

A high efficiency coil is available as option (BAE) for projects where the input water temperature is higher so as to maximise operation of the cooling units serving the Data Centre in free cooling mode.

A stainless steel condensation collection basin is installed at the base of the coil, complete with fitting for drain and siphon.

DUAL HYDRAULIC CIRCUIT (DW units)

Different solutions are available in dual hydraulic circuit DW units to manage the two existing circuits.

- **Parallel mode**

The controller manages both circuits in parallel in this case. The two valves open or close similarly, according to the temperature that needs to be controlled.

- **In-series mode**

In this case the controller manages the control band opening the valve in one circuit. When this is no longer enough, the system requests operation of the second circuit as well.

This solution may be applied, for instance, when one of the two circuits is connected to a more cost-effective source (dry cooler, chiller free cooling) and it is used as primary source.

- **External alternating mode**

The controller switches from one circuit to another based on an external signal in this case. A BMS can pilot the two alternating circuits with the help of an electric signal.

- **Automatic alternating mode**

A dedicated option is required for this mode. In this case switching from one circuit to the other is directly implemented by the unit controller, based on the temperature and water flow conditions.

ELECTRICAL CONTROL PANEL

The electrical panel located in a dedicated compartment and separately from the air flow is made in accordance with IEC standards. It includes:

- a main power switch;
- automatic switches for the power circuit and the auxiliary circuit;
- contactors for power loads;
- a transformer to separate the power lines of the power circuits and the control circuits;
- a microprocessor electronic controller;
- an auxiliary terminal board for the electrical connection of loads and external signals/ok signals.

The electrical control panel is always accessible from the front part of the unit. The main power switch is supplied with a door lock handle that prevents opening of the electrical control panel door if the power supply is enabled. The electrical control panel is structured in such way that it meets protection level IP42.

The microprocessor controller inside the electrical control panel is provided with the following functions/features:

- display showing the return air temperature;
- Humidity (with specific option)
- display showing the temperature in the delivery line;
- display showing the fan speed;
- two-level alarm message(s) (serious alarm and minor alarm);
- log recording of the last 100 alarms;
- operating hour meter;
- display showing the status of the controlled devices;
- display showing the status of inputs and outputs of the microprocessor.

Power supply [V/ph/Hz]: 400/3~/50 ±5%.

The following potential-free contacts are supplied in the terminal board as standard:

- remote ON/OFF;
- serious alarm;
- minor alarm (message).

BLUE THINK DATA

The Blue Think Data software fully incorporates the know-how and expertise of Swegon-Blue Box in Data Cooling applications. Blue Think Data is developed and constantly updated in-house through a continual improvement process.



Blue Think Data was conceived for the best functionality of the various units and systems installed in multiple machines, and at the same time it guarantees the highest safety level for both the components and application.

Blue Think Data incorporates the following key functions:

- control of return temperature;
- control of delivery temperature;
- delivery temperature restriction;
- control of either relative or absolute humidity in the return line (only applies to units with the necessary sensor and/or humidifier);
- Multiple solutions for ventilation control (with relevant options)
- advanced alarm management: recording of 100 alarms in the memory, division of alarms into two categories (minor and serious alarms), smart automatic reset;
- auto restart after a voltage failure;
- function for quick restart (only if the Black Out Restart option has been selected);
- function for absorption limitation, which is implemented either via the setting of a limit absorption value or via an external digital request signal (only if the relevant options have been selected);
- integrated clock for timer-controlled switch-on/off and setpoint variation according to time bands;
- password-protected levels of access to parameter setup pages, protection against undesired tampering or tampering by unauthorised/non qualified staff;
- multi language interface, which the operator can select in real time;
- management of multiple locally networked units (up to 32) for integrated and optimised operation (if the corresponding option has been selected).

Specific functionalities (e.g. Local Network, Air free cooling, Ventilation) and set-up solutions are illustrated in more in-depth details in the relevant sections.

The graphic interface was designed for immediate feedback on the operating condition as well as for easy and efficient access to the various functionalities.

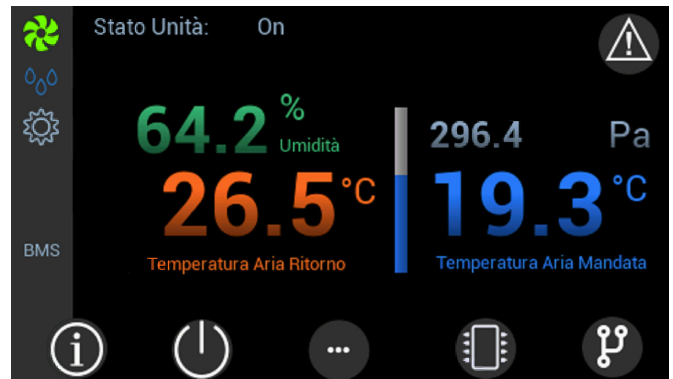

The standard unit offers the following control system interfaces, which are always included and active:

- a Modbus RS485 serial port for reading and writing purposes;
- a RJ45 port for IP communication, including a reading and writing Modbus TCP/IP, available as standard.

Supervision via WEB is always available with the RJ45 port. When the machine IP address is queried via web browser from any computer connected to the same local network to which the units are linked, access can be gained to the unit web page (password-protected access).

This solution is especially convenient and efficient to view the machine status or to perform maintenance. The solution does not require any dedicated software or hardware and it gives access to a set of graphs which are launched to monitor the trends of the main operating parameters of the unit in real time (temperature, humidity, air flow rate, etc.).

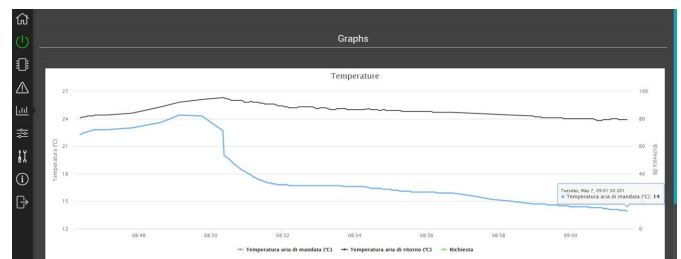

HARDWARE

The operating hardware consists of the following elements:

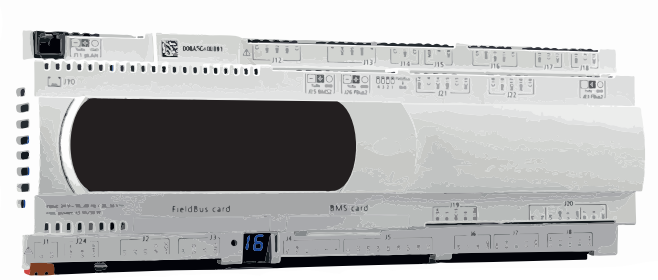

input/output boards including a 32-bit, 100 MHz microprocessor, with a 128-Mbyte non-volatile (FLASH) memory, 90Mbyte of which are available as file storage, and a 16 Mbyte data memory (RAM). Three different board sizes are used to optimise the number of inputs and outputs with respect to the application;



a humidifier-specific I/O board (which is therefore only fitted if this option is selected) communicating with the master board in serial mode;



The graphic terminal is a 4.3" touch screen panel. The electronic technology featured and the 65.000 colour display help manage high quality images and advanced functions. The touch screen panel is also designed for easier man-machine interaction as it makes screen browsing much more user-friendly.

The display is also supplied with a LED bar featuring different message-associated colours. The machine status can be viewed at any time without having to go close to the display.

Another innovative feature is the front position of the USB outlet for easier access without the use of specific tools.

Type	LCD TFT
Resolution	480 x 272 Wide
Display active area	4.3", diagonal
Colours	67 K
Back-lighting	LCD - Lifetime 20k hrs @ 25 °C
Touchscreen	Resistive
System LED indicators	8-colour notification bar

TESTING

All units are leak tested for possible leaks. Units are filled with a nitrogen and helium mix at 8 Bar. The circuit is pressurised and left in such condition for a predefined period of time (which varies according to the mix used), after which the pressure level is tested. The entire circuit is also checked for micro leaks with a sniffer.

The units are then subjected to a functional test which includes the following, among others:

- inspection that the correct options are fitted and the necessary documentation is available;
- software uploading in the unit controller and parameter setup, based on the unit and the featured options;
- inspection that the probes can read correctly and probe calibration, where necessary;
- functional dry run testing.

The units are finally delivered as follows:

- with nitrogen-filled hydraulic circuit.

PACKAGING AND SHIPMENT

Units are always shipped with the air handling unit and the fan section separated. The air handling unit is anchored to a pallet and it is protected with angular pieces made of expanded polyurethane. Then unit is then wrapped in stretch film for greater protection.

The fan section is anchored to a pallet and packaged as specified for the air handling unit.

DESCRIPTION OF ACCESSORIES

AERULIC CIRCUIT OPTIONS

AF Dirty filters alarm

Differential pressure sensor used to monitor any head loss through the filters and to warn about the critical threshold setpoint having been exceeded



PLRI Air return plenum

Plenum enclosed on the four sides and open at top and bottom To be used with downflow units (Under) as intake plenum The plenum must be installed on top of the unit.

The plenums have the same construction features as the units: sandwich panels of the same thickness and insulation. Plenums are supplied with the installation kit, complete with the necessary instructions and assembly hardware.



The height of a standard plenum is 600 mm.

Dimension table relating to both intake plenums (PLRI) and vertical air delivery plenums (PLMV):

Cabinet type		S	S-M	M	M-L	XL	XXL
Height	mm	600	600	600	600	600	600
Width	mm	1100	1350	1750	2150	2650	3305
Depth	mm	890	890	890	890	890	890

PARI Fresh air intake with filter

Each unit can be equipped with a fresh air intake to mix the air returning from the environment with a limited amount of air taken from the external environment (5% to 10% based on work conditions). The air inlet - 100 mm in diameter - is supplied with a filter, filtration class ISO Coarse 45% (under ISO 16890-3, corresponding to G3 EN779), and it is positioned in such way as to introduce fresh air downline of the evaporating coil.

FEU5 High efficiency filters ISO ePM10 50% (M5)

The units are available with filters having a greater filtration level than standard. This purpose is served in particular by a filter, class ISO ePM10 50% (under ISO 16890-3, corresponding to M5 EN779). The filtering material (synthetic fibre) is optimised to guarantee the required filtration class and, at the same time, to minimise the head losses on the air side.

FF6 High efficiency filters ISO ePM10 75% (M6)

The units are available with filters having a greater filtration level than standard. This purpose is served in particular by a filter, class ISO ePM10 75% (under ISO 16890-3, corresponding to M6 EN779). The filtering material (synthetic fibre) is optimised to guarantee the required filtration class and, at the same time, to minimise the head losses on the air side.

FF7 High efficiency filters ISO ePM1 50% (F7)

The units are available with filters having a greater filtration level than standard. This purpose is served in particular by a filter, class ISO ePM1 50% (under ISO 16890-3, corresponding to F7 EN779). The filtering material (synthetic fibre) is optimised to guarantee the required filtration class and, at the same time, to minimise the head losses on the air side.

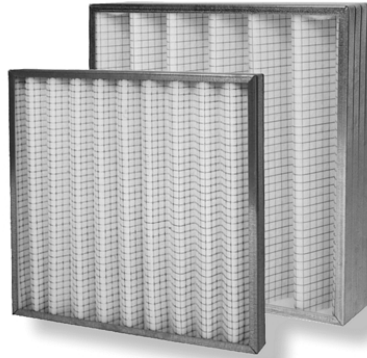

SEMO Motor-driven air non-return shutters

Air non-return shutters are available for both down- and upflow units and they isolate the unit from the system when the unit is off. This is, for instance, a solution to prevent the air bypass due to nearby units (where one is in operation and the other is in standby).

Motor-driven shutters are made of galvanised steel and have a leverage-controlled motion transmission system between the elements. Shutters are placed in a 150 mm tall module installed on top of the unit which includes the shutter itself and an On/Off servo control. The solution with a module covering the shutter perimeter was studied for optimised quality from an aesthetic point of view (same panelling and finishing as the unit) and from the standpoint of safety (no risk of crushing in the shutter, sharp corners/edges in the frame guarded with aluminium pieces, no risk for limbs resulting from lever mechanisms or blades).

The solution also includes installation of the servo control at the front and a dedicated panel for access. The arrangements above remarkably improve accessibility if compared to solutions with a side servo control and they offer the opportunity to install the units side by side.

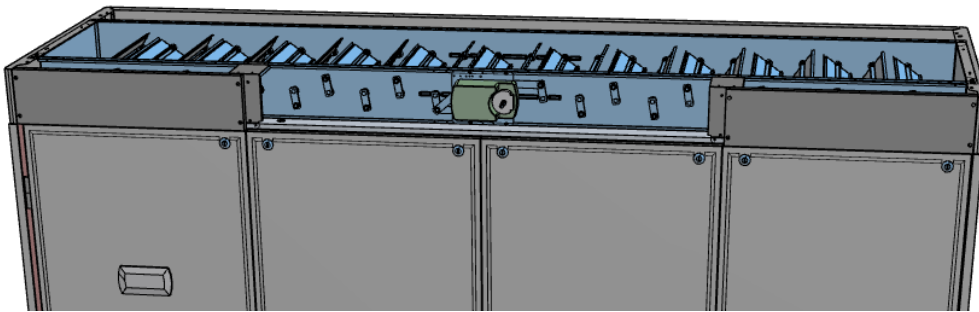

If there is not enough space to install a shutter or a physical upgrade is not possible although such functionality is needed, the machine software offers the **Virtual Damper** feature. This solution is designed to enable units in standby (other than for an alarm) to keep the fan running at low speed. It is managed by the controller (<=10%) to avoid the air bypass.

ASPS Fan section open for raised underfloor mounting (S)

The fan section of the unit is installed underfloor in this version. This solution provides for the best efficiencies, as the fans are free to blow the air in the most efficient and convenient way.

The height of the fan section is 700 mm. If the floor height is greater, a base frame solution shall be adopted to make up for the height difference. If the floor height is lower, on the other hand, a dedicated option is available to reduce the free section of the fan module and to adapt it to every specific installation.

For easier underfloor installation, the fan section is supplied as standard with legs (for accurate adjustment of the unit height with respect to the floor level) and a support for the tiles positioned near the fan section.

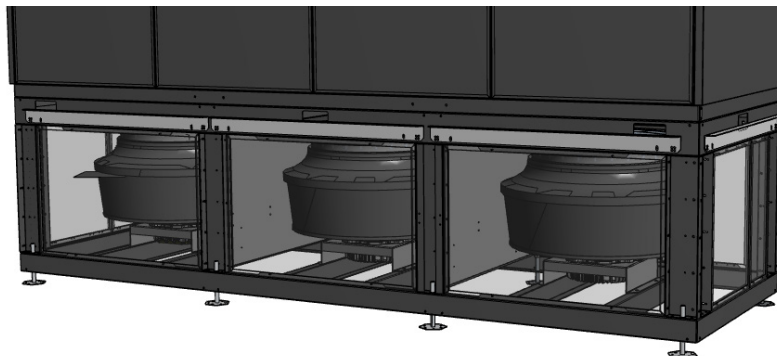

CSPS Fan section enclosed on all 4 sides for overfloor mounting

This solution includes an enclosure on all sides, so only downflow delivery is possible. The machine can thus be used as a traditional "downflow - under" version on a raised floor.

EOGA Fan section enclosed on 3 sides with front air delivery

This solution includes an enclosure on 3 sides of the fan section with a front ejection grid for direct air blowing into the environment. The machine can thus be used in cases where there is no raised floor.

EOCC Fan section enclosed on 3 sides with back air delivery and channelling option

Fan section enclosed on three sides with back connection flange for channelling and underflow air blowing. The machine can thus be used in service aisles, maximising the space available for IT equipment.

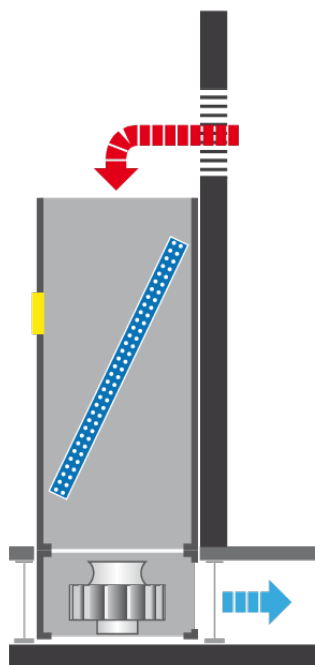

KP Kit for floor heights <700 mm

If the floor height is below 700 mm (but greater than 450 mm), a dedicated kit is available to install the fan module underfloor, in its most efficient configuration. The kit is made to measure, based on the specific floor height.

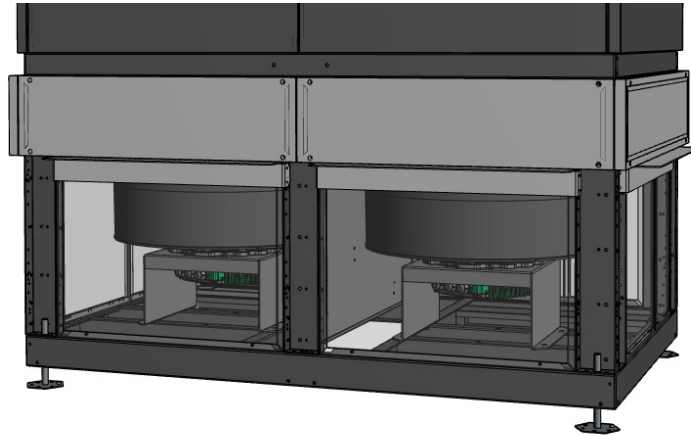

SPA Automatic air flow rate control

This solution enables making the most out of the advantage in efficiency offered by EC fans at partial loads. The unit will modulate the fans according to the room load (distance from the temperature setpoint to be checked). It will also adapt to any aerodynamic variations on site thanks to the back action on the air flow rate.

With the algorithm the exact amount of air required by the application is available at all times thanks to the constant measurement performed by a differential pressure transducer. The unit keeps the air at the reference value using a PID back action control algorithm which changes the fan speed whenever the external conditions change.

Please find a simplified list of the implied steps below:

- load change;
- change of controlled temperature;
- calculation of fan speed and of expected air flow rate;
- feedback of flow rate actually measured based on the site conditions (on-site losses, progressive filter fouling, etc.);
- new fan speed.

The Bernoulli's principle is the physical principle referenced to measure the air flow rate: the fan intake nozzle, which may be compared to a bottleneck, causes a pressure reduction which is affected by the geometrical features of the nozzle and of the air flow rate.

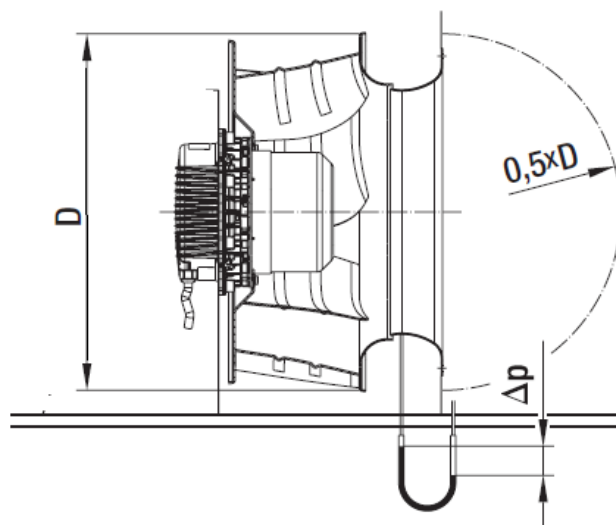

The simplified formula which summarises the link between the air flow rate and the pressure difference inside and outside the nozzle is as follows:

$$\dot{V} = k \times \sqrt{\Delta P}$$

V = air flow rate in m3/h
 k = geometrical constant of nozzle
 ΔP = pressure difference in Pa

CPA Pressure control in air delivery line

This option is used to check the radial fan speed required to keep the pressure setpoint (ESP) constant in the floor or in the delivery line. Units are therefore supplied with an internal pressure outlet (placed on the return line) and one outlet at the control point. This sensor can only be used for positive pressures.

If multiple units operate in the same area, the regulation value may be set to the min.-medium-max. pressure value sensed by each individual transducer.

Min ESP	0 Pa
Max ESP	100 Pa

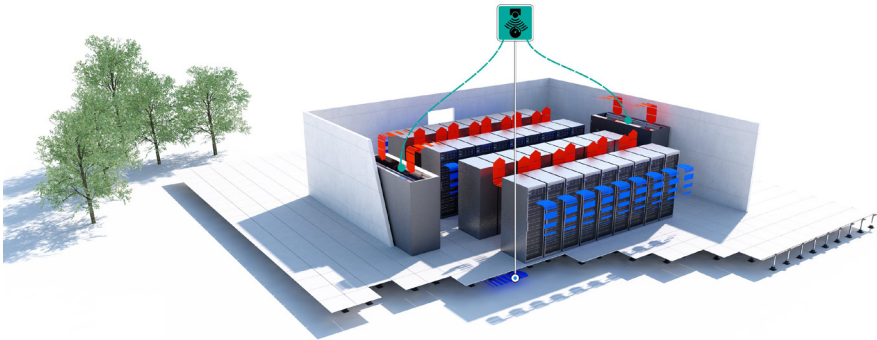

CPR Remote pressure delta control

This option is used to check the radial fan speed required to keep the differential air pressure setpoint constant. Units are supplied with a differential sensor with two pressure outlets to be fitted remotely. The sensor is used to check values around zero, i.e. with pressures that switch from negative to positive and vice versa. This is the ideal solution to contain the cold or hot aisle and it contributes to the optimisation of the air flows as it balances the unit flow rate with the server-processed flow rate through pressure balancing in the compartmentalised aisle.

If multiple units operate in the same area, the regulation value may be set to the min.-medium-max. pressure value sensed by each individual transducer.

This option is similar to CPA: the only difference is that both transducers in the sensor must be installed remotely. The sensor will also be used to check values around zero, i.e. with pressures that switch from negative to positive and vice versa.

Min ESP	-50 Pa
Max ESP	+50 Pa

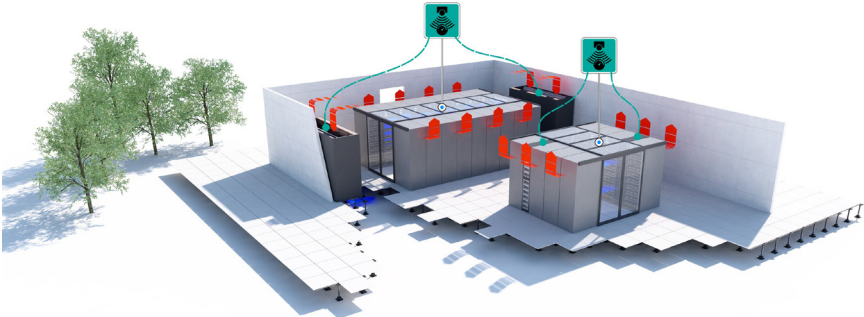

HYDRAULIC ACCESSORIES

PSC Condensate booster pump

This pump is used to boost condensate that may have formed on the cooling coil and is collected in the condensate tray. It is also used in units featuring a dehumidifier to manage the water exhausted by this device. The condensate exhaust pump is supplied separately from the unit (it is not installed in the unit), but provision is made in the electrical control panel for protections and an electrical connection, plus an alarm signal. The pump is always duly sized for correct unit operation within the stated operating limits.

All sizes Main specifications

- Length: 195 mm
- Width: 130 mm
- Height: 135 mm
- Power supply: 230 V - 1 ph - 50/60 Hz
- Max. absorption: 90 W

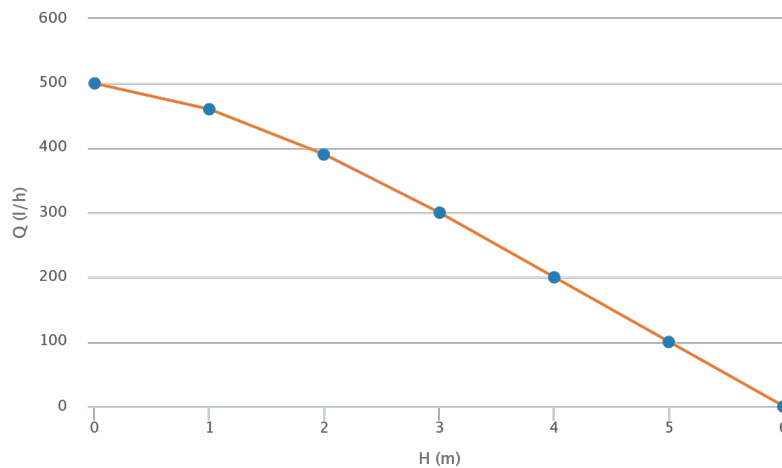

COID Upward hydraulic connections

If the layout of the site requires so, dual-circuit units can be supplied with hydraulic connections facing upwards and one circuit on the left and the other on the right.

CIAD Hydraulic connections on top RH side

If the layout of the site requires so, single-circuit units can be supplied with hydraulic connections on the top right-hand side.

CIAS Hydraulic connections on top LH side

If the layout of the site requires so, single-circuit units can be supplied with hydraulic connections on the top left-hand side.

CIBS Hydraulic connections on bottom LH side

If the layout of the site requires so, single-circuit units can be supplied with hydraulic connections on the bottom left-hand side.

V2R 2-way chilled water valve

A 2-way valve may be requested for all chilled water units, which basically consists in a 3-way valve with the bypass line closed.

This solution is typically applied in variable water flow rate systems where one or multiple pumps featuring an inverter or another device for flow rate change are used to adjust the water flow rate to the actual thermal load.

The 2-way valve is not compatible with the option "No water flow alarm" as the system would generate an alarm any time the valve is closed as a result of ambient temperature setpoint achievement.

V2RP Two-way primary chilled water valve

This option only applies to dual circuit units (DW). The 2-way valve in this case is installed on the primary circuit.

V2RS Two-way secondary chilled water valve

This option only applies to dual circuit units (DW). The 2-way valve in this case is installed on the second circuit.

CAB Automatic switching between circuits (DW units)

This option provides for automatic switching, which is an extra mode to manage the two circuits in addition to those illustrated above. If the conditions of the primary circuit are no longer suitable for correct unit operation (in terms of water supply and/or temperature), the controller automatically switches to the second circuit.

If the unit features 3-way valves, the controller uses the mechanical flow switch and the input water temperature probe to evaluate whether the circuit is suitable for operation. If the unit features 2-way valves, the virtual flow switch solution is adopted.

The flow switch solution is designed to check the flow even in cases where a physical flow switch is not fitted. The unit periodically opens the valve in the primary circuit (based on a settable time) and indirectly checks whether there is water flowing in the circuit (by calculating the T delta in the coil). If the T delta is zero (no water flow in the circuit), the controller repeats the operation after the selected time.

SIOA Input/output water temperature probes

Chilled water circuits can be fitted with an input and output water temperature probe for viewing/monitoring purposes only. The measured values are shown on a display, but they do not cause any changes to be made to the regulation and control logic.

FLM Water flow meter

Chilled water circuits can be fitted with a flow meter for viewing/monitoring purposes only. The measured value is shown on a display, but it does not cause any changes to the regulation and control logic.

Flow meters are supplied bulk for installation by the customer.

UMEI Immersed electrode humidifier

With the option, the unit can be equipped with an immersed electrode humidifier that humidifies the air in cases where the air is extremely dry, if compared to the setpoint stored.

The operating principle of the humidifier is as follows. A container featuring electrodes is filled with water until the electrodes are slightly covered, as water serves as the conducting medium between the electrodes. The Joule effect causes the running current to heat the water which evaporates as soon as it reaches the boiling point.

The output vapour is transferred to the environment. The solution with immersed electrodes is fully safe from a health standpoint and it is designed for proportional adjustment of vapour generation.



There are precise relationships between the humidifier potential and the absorbed power. Generally speaking, the following may be stated:

$$P = 0.75 \times Pv$$

where

P [kW] this is the absorbed power, expressed in kW;

Pv [kg/h] this is the generated vapour, expressed in kg/h.

Moreover:

$$I = \frac{P}{S \times \sqrt{n}}$$

where

I [A] this is the absorbed current, expressed in A;

P [W] this is the absorbed power, expressed in W;

S [V] this is the rated voltage, expressed in V.

n this is the number of phases in the power supply.

This shows a directly proportional relation between the absorbed current and the generated vapour, which may be summarised in the formula below:

$$Pv = \frac{\sqrt{n} \times S}{0.75} \times I$$

where

Pv [kg/h] this is the generated vapour, expressed in kg/h.

n this is the number of phases in the power supply.

S [V] this is the rated voltage, expressed in V.

I [A] this is the absorbed current, expressed in A.

The microprocessor controller proportionally adjusts the output steam, based on the humidification level required in the room, through the regulation of the current absorbed by the electrodes. Additionally, it controls all the operating phases: water filling and discharge, periodic emptying cycle, viewing of operating status and alarm messages. The end user will be able to select whether the control needs to be based on either relative or absolute humidity.

Upon request, the piloting of an external humidifier equipped with its own controller may be implemented with both a 0-10V signal and an On/Off signal.

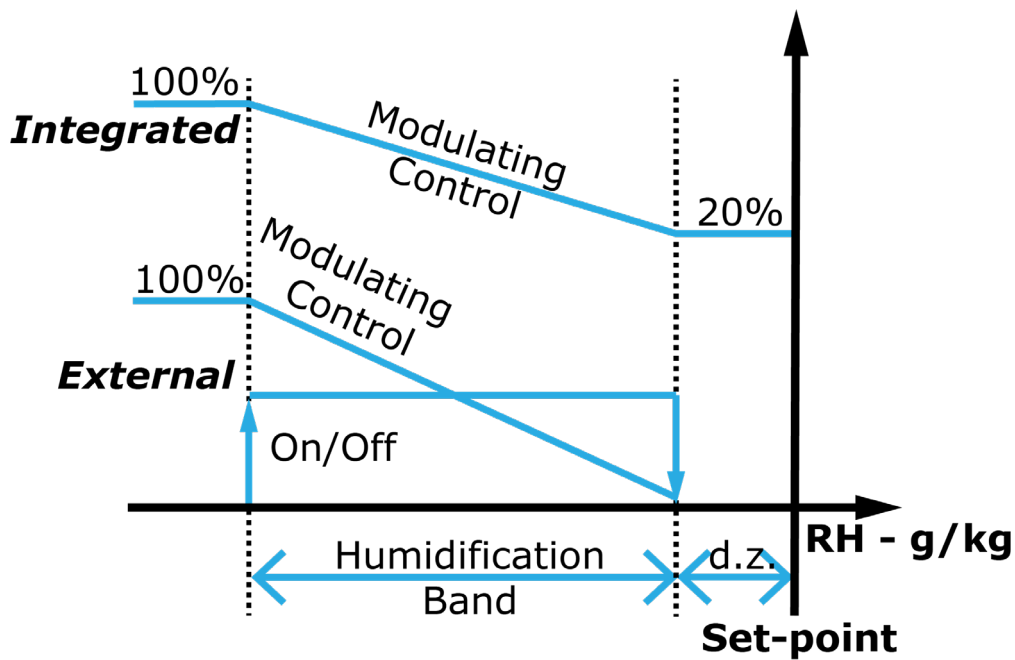

The table below shows the specifications of the humidifiers fitted on the units.

Cabinet type		S	S-M	M	M-L	XL	XXL
Max. steam output	kg/h	8	8	15	15	15	15
Max. absorbed power	kW	6	6	11.25	11.25	11.25	11.25
Power supply	V/ph/Hz	400/3/50	400/3/50	400/3/50	400/3/50	400/3/50	400/3/50
Water volume	l	6	6	10.3	10.3	10.3	10.3
Max. load capacity	l/min	4 c.a.	4 c.a.	4 c.a.	4 c.a.	4 c.a.	4 c.a.
Max. load capacity	l/min	0.6	0.6	1.2	1.2	1.2	1.2
Feed water conductivity	μS/cm	350-750	350-750	350-750	350-750	350-750	350-750
Filling fitting,		3/4" G, male	3/4" G, male	3/4" G, male	3/4" G, male	3/4" G, male	3/4" G, male
Drain fitting	mm	32	32	32	32	32	32

The humidifier cylinder is not designed for inspections and maintenance. A check should be made that the conditions of feed water to the humidifier are within the allowed limits. Consult the relevant installation, operation and maintenance manual for this purpose. Cylinders designed for inspection can be supplied upon request or cylinders for conductivity ranges other than standard.

BAE High efficiency coil for maximised free cooling

The best approach to maximise the annual efficiency of the entire chilled water system is to take the actual server needs as reference. The intake air required by the servers has a temperature ranging between 20°C and 27°C **ASHRAE (American Society of Heating Refrigeration Air-conditioning Engineers) Recommended Envelope**.

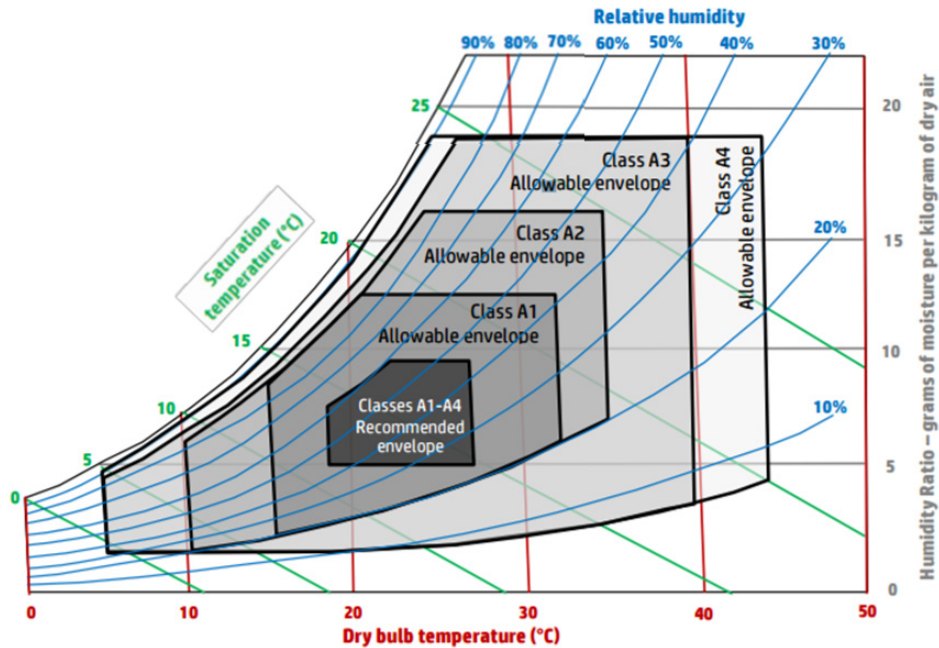

The idea is to optimise the system design in four simple steps:

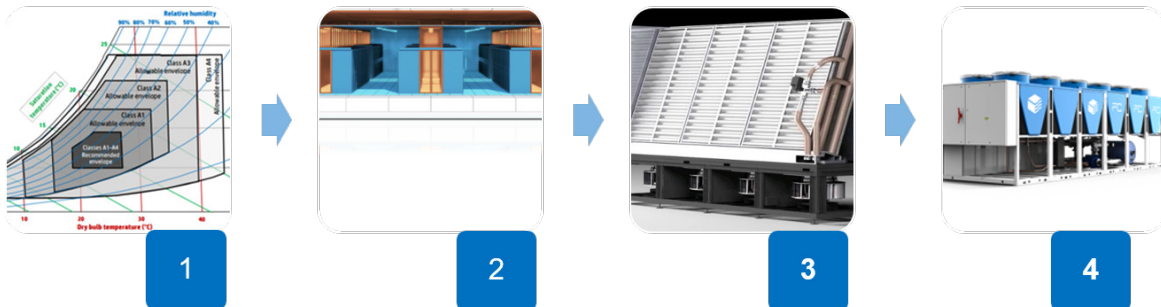

- 1 take the desired temperature in front of the servers as the starting point;
 - 2 implement the separation between hot and cold air (containment of either hot or cold aisle);
 - 3 use optimised units for water temperatures in connection with the desired air temperature (the output temperature is normally between the water temperatures in the coil. For instance: at an air temperature of 21°C/22°C, the ideal water temperature probably is 18°C - 24°C);
 - 4 maximize the opportunity offered by free cooling thanks to the higher water temperatures.
- Datatech PFW units featuring a BAE option have been designed exactly following this philosophy and they have been optimised for enhanced performances with higher water temperatures.

ELECTRICAL ACCESSORIES

FUOC Fire sensor

For fire detection with sensors placed on the unit or in its vicinity The sensor is a thermo-differential sensor and can perceive the speed with which the temperature is rising so as to react quickly to the currents of hot air from a fire. It can protect an area of 49 sq.m (7x7).

The sensor is supplied bulk for installation on site. As it operates correctly with air speeds below 0.2 m/s, it must be installed outside the unit (not inside it).

FUMO Smoke sensor

For smoke detection with sensors placed on the unit or in its vicinity This optical sensor is approved at national level by the Ministry of the Interior and it is type-approved at international level in conformity with harmonized European regulations CEN EN 54 part 7 and 8. It can protect an area of 81 sq.m (9x9).

The sensor is supplied bulk for installation on site. As it operates correctly with air speeds below 0.2 m/s, it must be installed outside the unit (not inside it).



The picture on the left shows a fire sensor (FUOCO - FIRE), whereas the picture on the right shows a smoke sensor (FUMO - SMOKE).

REFF 24V relay for remote smoke/fire sensor

If an external fire/smoke detection system needs to be connected to the units, a 24V relay may be required for connection of the potential-free alarm contact from the field to the microprocessor in the unit.

SAL Single-point flood sensor

The flood detection sensor is the recommended solution to monitor possible water leaks which are not visible to the naked eye, typically underneath raised floors. The single-point flood sensor (SAL) consists in a single-point sensor wired to the electrical control panel, which is provided with a long enough cable to position the sensor close to the unit.

The microprocessor warns about the relevant alarm and either switches off the unit or not, based on the selected alarm configuration (serious alarm or simple message).

SA2 2 x Single-point flood sensor

SA2 consists of two single-point sensors: one sensor is wired to the control panel, the other is supplied bulk for installation on site at the required point.

SA3 3 x Single-point flood sensor

SA3 consists of three single-point sensors: one sensor is wired to the control panel, the other two are supplied bulk for installation on site at the required point.

SAN Tape extension flood sensor

The tape extension flood sensor (SAN) consists of a 25m long tape extension sensor. This solution provides for coverage of a larger area around the unit.



The picture shows both the single-point flood sensor (SAL) and the tape extension sensor (SAN).

ALMA No water flow alarm

For chilled water units (CW), this alarm is used to monitor the input water flow and to warn about flow missing in the form of a message reporting an alarm condition.

The flow meter is supplied bulk for installation by the customer.

This option is not compatible with the 2-way configuration.

**ALMT No voltage alarm**

The No Voltage alarm is a potential-free contact in the terminal board in the electrical control panel. It is closed when the unit is energised.

SCAL Alarm management card

The alarm management board is an extension of the microprocessor control board. It consists in a series of additional (solid state relay) digital outputs (up to max. 4, although the number is variable according to the machine configuration) which can be assigned to 21 different unit operating statuses. This allows for more accurate monitoring of the operating conditions through the remoting (with potential-free contacts) of individual operating statuses or specific alarms.

In addition to the above, the option is supplied with terminals that are directly linked to the digital inputs designed for connection of potential-free contacts for the purpose of:

- disabling the electrical heaters (where fitted);
- disabling the humidifier (where fitted);
- connecting a configurable external alarm.

CP Single potential free operating contacts

All standard units offer the opportunity to remote the signals/functions below through potential-free contacts:

- remote switch-on/off.
- serious alarm;
- Minor alarm (message).

If the configuration is supplemented with the CP option, potential-free contacts are made available in addition to those listed above for the following purposes:

- fan status;

A41 Power supply 415 V - 3 ph - 50 Hz

415V power supply for three-phase sizes in the range which do not require a neutral. The neutral is applied when the internal unit is required to power a single-phase component (remote condenser, remote single-phase dry cooler, condensate exhaust pump) or whenever dual power supply with automatic switching is needed.

A41N Power supply 415 V - 3 ph - 50 Hz + N

415V power supply for three-phase sizes in the range which require a neutral. The neutral is applied when the internal unit is required to power a single-phase component (remote condenser, remote single-phase dry cooler, condensate exhaust pump) or whenever dual power supply with automatic switching is needed.

A46N Power supply 380-400 V - 3 ph - 60 Hz + N

380-400 V / 60 Hz power supply for three-phase sizes in the range which require a neutral.

The neutral is applied when the internal unit is required to power a single-phase component (remote condenser, remote single-phase dry cooler, condensate exhaust pump) or whenever dual power supply with automatic switching is needed.

Only applies if the machine is provided with EC fans.

A46 Power supply 380-400 V - 3 ph - 60 Hz

60Hz power supply without neutral (380 - 400V voltage) for three-phase sizes in the range.

The neutral is applied when the internal unit is required to power a single-phase component (remote condenser, remote single-phase dry cooler, condensate exhaust pump) or whenever dual power supply with automatic switching is needed.

A463 Power supply 460 V - 3 ph - 60 Hz

60Hz power supply without neutral (460V voltage) for three-phase sizes in the range.

The neutral is applied when the internal unit is required to power a single-phase component (remote condenser, remote single-phase dry cooler, condensate exhaust pump) or whenever dual power supply with automatic switching is needed.

Only applies if the machine is provided with EC fans.

DAA Dual power supply with automatic switchover

This allows immediate automatic switching to the other source if one of the two power supplies fails, in order to maintain continuity of service in installations where high redundancy is required. This obligatorily requires a dual power supply system.

As the two sources do not switch instantly, the unit will be switched off, first, and then switched on automatically. If controller switch-off is to be avoided, thus reducing the subsequent switch-on times, a capacitive condenser (BORU) is available as option to keep the controller operational during the switching phase.

This solution necessarily requires that the power cables be supplied with a neutral.

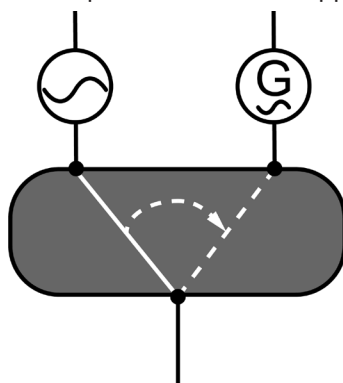

BORU Blackout restart

For quicker restart after a power failure (blackout), the unit can be supplied with capacitive electrical condensers to keep the controller operational for 15 - 20 seconds (depending on its use). This allows for quicker cooling system restart as soon as the power supply is restored (or switches to the other line in cases with dual power supply).



LIID Limitation of the current absorbed by digital input

When this accessory is requested, a digital input is prepared in the terminal board to activate the forced capacity reduction of the unit to a set fixed level.

This option is useful when the power absorbed by the unit needs to be limited under particular conditions.

The controller enables selection of the components to be disabled during forced operation (e.g. electric heaters, humidifier, 1 compressor in units with multiple compressors, etc.).

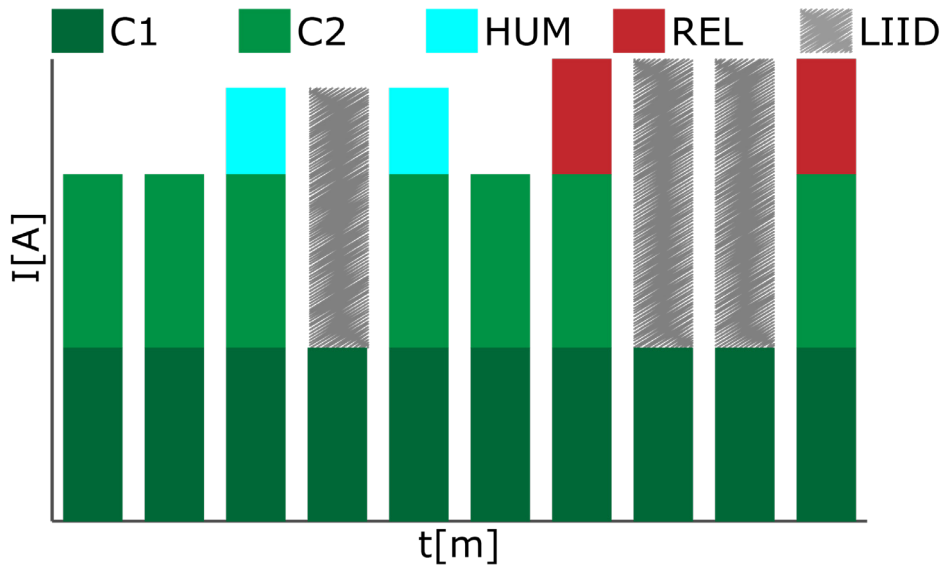

Example of operation of dual-compressor units with LIID configured to disable the compressor in second circuit, the electric heaters, the humidifier.

C1 Compressor in primary circuit

C2 Compressor in second circuit

REL Electrical heaters HUM Humidifier

LIID Time for which LIID is active

I [A] Absorbed current in A t [m] Time in minutes

ENML Energy meter with current limiter

The accessory allows the main electrical quantities (including voltage, current, power) to be read on the three phases, via current transformer.

This accessory communicates with the BlueThink controller to supervise the monitored data. The values measured are then made available through the unit display and the web server.

This accessory is designed to limit the maximum current the unit can absorb. The controller instantly checks the absorption levels and, where necessary, it applies a forced capacity reduction that keeps the absorbed current value below the stored threshold.

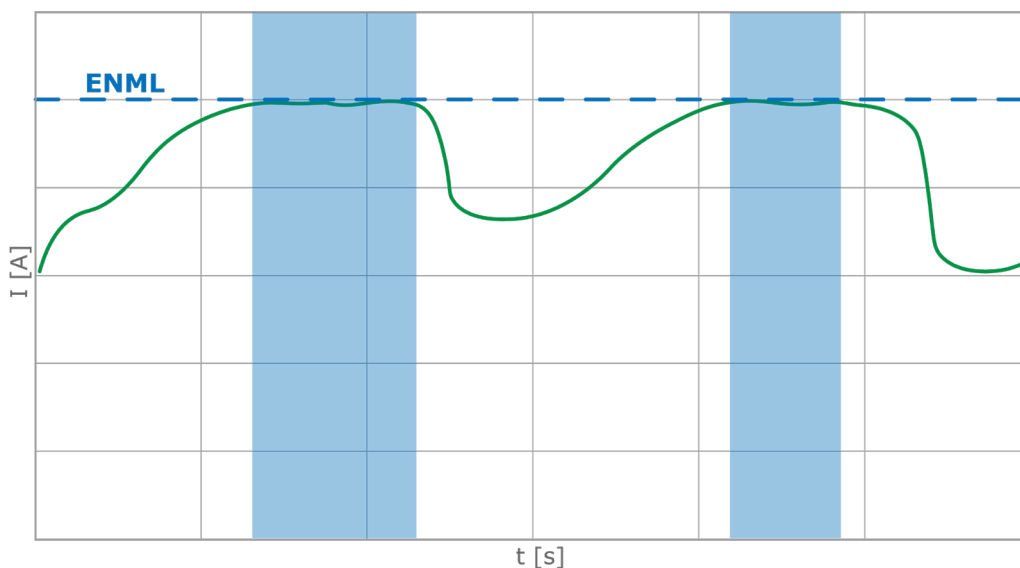

Picture exemplifying tripping of the function for absorption reduction when scalable devices are engaged.

MUSR Multi sensor (4) on return line

Solution with 4 sensors detecting the return temperatures and calculating the average for multi-point reading of the temperature and for more accurate temperature regulation. The option is supplied separately from the unit and it must be wired on site, based on the specific length requirements of the application layout.

The option connection cable to the unit is 5m long and the cable of each sensor is 6m long.

MUSM Multi sensor (4) on delivery line

Solution with 4 sensors detecting the delivery temperatures and calculating the average for multi-point reading of the temperature and for more accurate temperature regulation. The option is supplied separately from the unit and it must be wired on site, based on the specific length requirements of the application layout.

The option connection cable to the unit is 5m long and the cable of each sensor is 6m long.

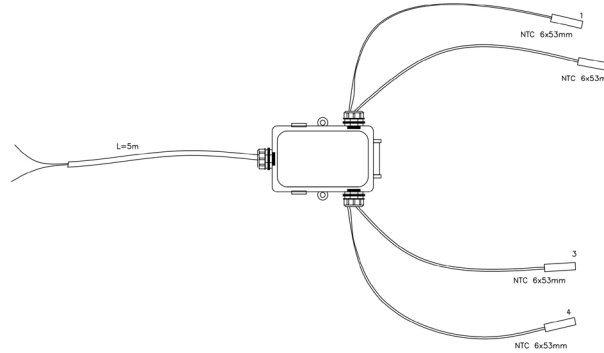

SUM Probe for humidity indication

This probe is available for cool only or cool and heat units and it is used to view the return humidity and the de-humidification value.



TR1 1 x Remote temperature sensor

This option is used to command temperature regulation and ventilation based on the values measured by a sensor that is installed in a remote position from the unit (at a max. distance of 30m) and in a closer position to the equipment that requires conditioning.

Where multiple units are fitted, each unit can be supplied with one sensor and the operator can choose whether to use the min., medium or max. value as the reference value.

TUR1 1 x Remote temperature and humidity sensor

This option is used to command temperature regulation and ventilation and to regulate humidity (either relative or absolute) with the help of a sensor installed in a remote position from the unit (at a max. distance of 30m). in a closer position to the equipment that requires conditioning.

Where multiple units are fitted, each unit can be supplied with one sensor and the operator can choose whether to use the min., medium or max. value as the reference value.

TR2 2 x Remote temperature sensor

This option is used to command temperature regulation and ventilation with the help of two sensors installed in remote positions from the unit (each at a max. distance of 30m). The setpoint of the reference value can be the min., medium or max. value of both sensors.

Where multiple units are installed, the value (min., medium, max.) can be calculated as an average of the measurements by all featured sensors.

This option is also designed for use of the T Delta controller. This controller solution is conceived to balance the air flow rate processed by the conditioners with the air flow rate processed by the servers in the most accurate and continuous way possible.

The controller can pilot machine ventilation in such way that the difference (delta) between the unit input and output temperature is equal to the difference processed by the servers. For instance. If the application has either hot or cold aisle containment, the regulation of the cold source (compressor / valve) can be set to keep the delivery temperature constant and the fan regulation can be set so that the T delta between the input and output temperature (and the air flow rate as a result) is equal to the delta measured between the front and the back of the servers (including their flow rate).

The efficiency of this solution is enhanced with multiple units. When multiple units are fitted, a higher number of remote readings will be available and their min., medium and max. values can be processed.

The controller changes the fan speed iteratively, according to a logic by which the speed is either increased or reduced until the controller senses the correct air flow. For instance. When the delta temperature processed by the units is greater than the remote reference delta temperature, the controller will increase the fan speed through a small incremental step. The opposite will apply if the delta temperature measured in the machine is smaller than the remote reference delta.

The control is thus extremely regular and precise and brisk actions on the ventilation system are prevented, which may eventually disturb the conditions in front of the servers.

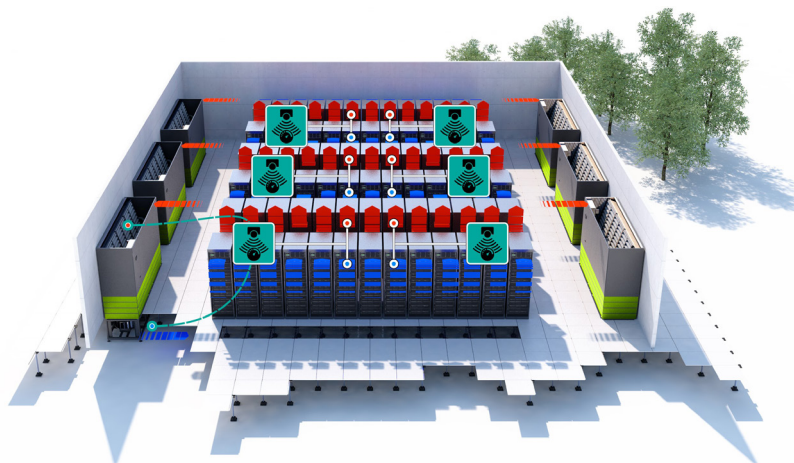

TUR2 2 x Remote temperature and humidity sensor

This solution is under all aspects equivalent to the solution with two sensors for remote temperature detection only (each at a max. distance of 30m from the unit). The only significant difference is that the remote sensors in this case can be used to also manage the control of the overall humidity in the room.

TR3 3 x Remote temperature sensor

This option is used to command temperature regulation and ventilation with the help of three sensors installed in remote positions from the unit (each at a max. distance of 30m). The setpoint of the reference value can be the min., medium or max. value of both sensors.

Where multiple units are installed, the value (min., medium, max.) can be calculated as an average of the measurements by all featured sensors.

TUR3 3 x Remote temperature and humidity sensor

This option is used to command temperature regulation and ventilation, and to regulate humidity (either relative or absolute), with the help of three sensors installed in remote positions from the unit (at a max. distance of 30m). The setpoint of the reference value can be the min., medium or max. value of both sensors.

Where multiple units are installed, the value (min., medium, max.) can be calculated as an average of the measurements by all featured sensors.

PCS Provision for button engaging the shutter preventing external air return

This option is designed to provide for an on/off signal to pilot the shutter that prevents the return of external air (the shutter is not supplied with the unit). The option includes the controller only: it does not include the devices required to power the shutter servo control. The control is implemented in such way that the machine can operate safely and possible conflicts are avoided between the position of the shutter and the unit controller. Compatible option for units with EC fans only

REL Electrical heaters

This option is designed to equip the unit with electrical heaters that are used to control heating and/or post-heating.

The heating elements are made of AISI304 steel and have low surface temperature, spiral AISI304 steel fins featuring a safety bimetal thermostat. Elements are grouped in banks made of galvanized sheet metal with a locked electric box.

The electric heaters are controlled according to power steps (either one or two depending on the unit size).

- Frame S 1 power step.
- All other frames: 2 power steps.

The execution with three power steps is available upon request. Binary management is implemented in this case: Step 1, Step 2, Step 1+2.

REM Oversize electric heaters

Oversize electric heaters provide for greater heating power - approx. 50% greater on average.

The power increase is approx. 30% for frame sizes SXS.

For punctual and precise values, refer to the technical specification tables given in the dedicated section of this document.

The ideal application of oversize electric heaters is in laboratories and metrological rooms where there is a poor sensible thermal load.

The option is not compatible with 460V/60Hz power supply.

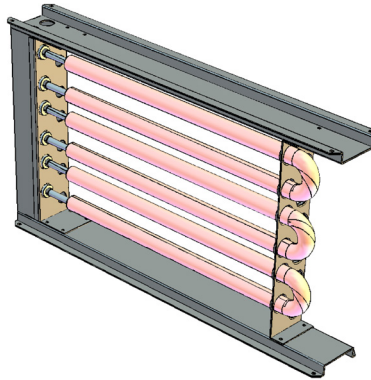

CRE Control for modulating electric heaters

If the unit is fitted with electric heaters, modulating heaters can be selected in place of step heaters. Triac-controlled electric heaters can follow the condition of the room with accuracy, thus improving efficiency in heating and post-heating operation.

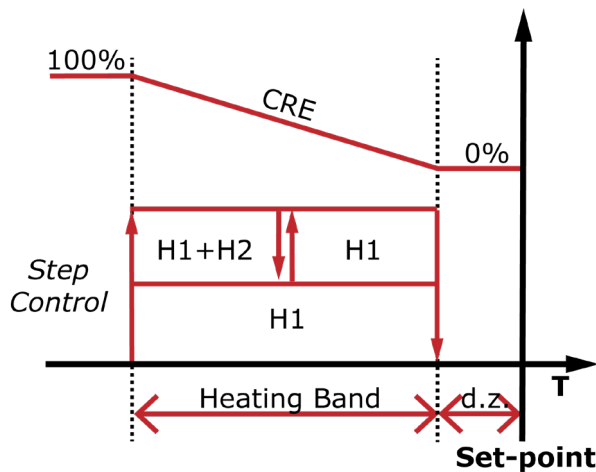

CWDS Chilled water dynamic setpoint

A chilled water system consists of two separate sub-systems: internal units and external chillers (possibly, free cooling type). At partial loads and with a constant flow rate to the primary circuit (or a variable flow rate below the min. flow rate thresholds), the chiller system outputs water at the standard setpoint and this water is then partially recirculated either inside the unit (3-way valves) or through the flow separation system (tank, piping, etc.). This reflects into a system energy inefficiency.

As the highest amount of energy is consumed by the chiller unit, in the ideal operating condition the chiller setpoint should be modified dynamically so as to deliver water to the air conditioners at the highest temperature possible, compatibly with the thermal load. This exponentially improves the system efficiency: as the water temperatures are increased, evaporation improves (in direct expansion mode) and the hours of free cooling increase remarkably.

Solutions have been developed over time to increase the water setpoint of the external chiller unit in an inversely proportional manner, for instance, through a 0-10V proportional signal upon an internal load request. This type of solutions only partly responds to the needs of modern Data Centres. The 0-10V only is a strong limitation in terms of point to point connection of each individual machine (when the connection is lost, the signal is lost too). Additionally, it does not efficiently provide for temperature control on the air delivery line (a far more critical factor as it directly impacts the temperature in front of the servers).

With the CWDS option, direct and smart communication is guaranteed between the set of internal machines and the external chillers, which are supplied by Swegon-Blue Box. Communication is not implemented through one single analog signal, but via continuous exchange of information at a higher level.

This is how internal units dynamically change the water setpoint of the connected chillers, based on the cold water valve position. More specifically, the more the valve is closed, the more the water temperature setpoint is increased; on the other hand, if the valve tends to its max. opening, the internal units will require the chillers to reduce their water setpoint. This prevents sudden disturbance to negatively affect the temperature/pressure in the room.

The aim of the logic is to stabilise the water temperature to such condition that the valve opens in the area where its energy consumption is optimised, leaving a margin for reaction under sudden peak loads, if any.

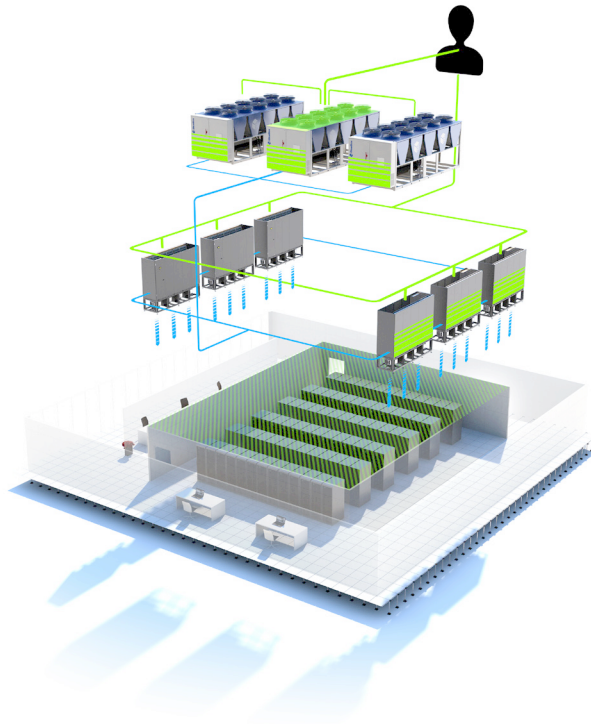

The picture above shows an example of a typical system featuring a set of internal units and a set of external free cooling chillers.

The solution with smart communication between internal and external units, however, offers the opportunity to provide for solutions with one-to-one systems. This solution requires that each single unit be connected to one single external free cooling chiller. Although it may appear to be less cost-effective, this solution actually is, if the concept of redundancy is added to the equation.

Example.

- Traditional design: 500 kW load handled using 5+1 internal units, 100 kW each, and 2+1 external free cooling, multi scroll chillers, 250 kW each; uncoupled primary and secondary pumping systems.
- One-to-one design: 500 kW load handled using 5+1 internal units, each connected to a free cooling, scroll inverter chiller, 100 kW; direct pumping system between chiller and internal unit, with inertia tank directly installed onboard the chiller.

The economic result generated by the chiller section only (as determined by comparing the investment in the chillers only, excluding pipes, tanks and pumping systems) gives a **saving of 15% in one-to-one design**. The above applies even if the units included in the second solution offer an additional inverter on the compressors. The reason for this is redundancy. In a one-to-one system the exceeding cooling capacity can be reduced to cover the N+1 demand, which is the very reason for the above-mentioned saving.

Moreover, a saving is also obtained at system level because of the reduced number of tanks and pumping units.

This solution, however, only works if the system can be converted into a "system of systems". In this case, the CWDS option offers a set of solutions specifically conceived for this application.

- The internal units pilot the demand from the chillers according to the load (when an internal unit is switched on, the chiller is pre-activated to pre-cool the water in the circuit and to provide for greater temperature stability).
- If a unit or the chiller connected to such unit is alarmed, all units in standby start their dedicated chiller in quick start-up mode for better service continuity.
- Units in standby, if any, in systems featuring free cooling chillers are started up to increase the free cooling capacity, when the external conditions allow so.
- Every internal unit - free cooling chiller system will dynamically optimise the water temperature for maximised free cooling of each individual sub-system as well.

These advanced logics, including from the standpoint of energy savings, enable the one-to-one system of the previous example to obtain **an annual saving of 21%, as calculated taking the climate profile in Frankfurt as reference**, over the total energy consumed by the chillers and the pumping system in one year.

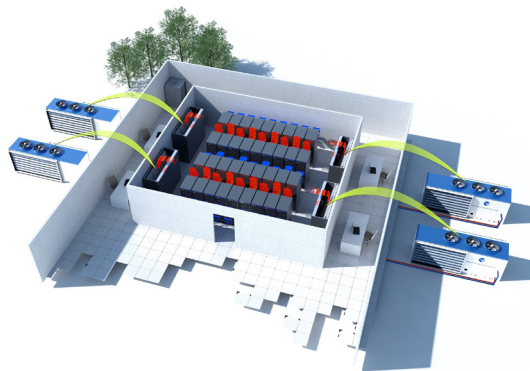

The one-to-one solution also offers an additional series of interesting advantages:

- the modularity and scalability of a direct expansion system combined with the effectiveness of a chilled water system with optimised free cooling;
- the possibility to implement a variable flow rate on the chiller in a simple and linear manner without the complications implied in a multi-machine system;
- a simplified layout and a very strong reduction of costs with TIER 3 or TIER 4 design.

NETWORK ACCESSORIES

BAC BacNet serial board

Serial connection boards allow connection to supervision and remote management systems, thereby making it possible to display the main operating parameters and edit the main operational parameters. The BacNet serial board allows connection to supervision systems with the MS/TP protocol.

The monitoring solution is BTL-certified (BACnet Testing Laboratories) and ensures that the system is developed and tested according to the highest standards in the industry.

This option is mutually incompatible with the GLO option (Gateway per Lonworks).



GLO Modbus Lonworks Gateway

With this accessory, a RS485/Lon gateway is installed inside the electrical control panel.

By default, the programming gives read-only access to the control of the unit. Enabling of read/write access should be requested when ordering.

This option is mutually incompatible with the BAC option (BacNet serial protocol).



PSN SNMP protocol

The accessory consists of a gateway that allows Ethernet connection to a SNMP manager supervision system.

SNMP

Simple Network Management Protocol

PBA BACnet protocol over IP (Ethernet)

The controller is set for use, in read and write mode, of the BACnet port on IP protocol.

By default, the programming gives read-only access to the control of the unit. Enabling of read/write access should be requested when ordering.

The monitoring solution is BTL-certified (BACnet Testing Laboratories) and ensures that the system is developed and tested according to the highest standards in the industry.



GRLD Datalink local network management

The local network Datalink is managed for communication among the various air conditioning units for the purpose of optimising system operation in terms of control efficiency and effectiveness. The local network Datalink is designed for connection of multiple Datatech BTD units (up to 32).



Management of the local network Datalink converts a set of multiple machines into one single smart system and is designed for the configuration of unit control in the system via different solutions.

- **Running-Standby** This function is intended to control redundant units that rotate together with the main units allowing for their homogeneous use and preventing possible conflicts between machines.

Units in standby can also be called up in the event of serious alarms occurring in the active units.

Finally, a function can be configured to call up units in standby if a Hot Spot is provided in the room.

This configuration is recommended with units having a fixed cold source (e.g. stationary compressors).

To address any localised hot spots, each single machine can be configured to automatically exit the network for a predefined time when peak loads need to be covered. As soon as the emergency condition has been solved, the units are networked again.

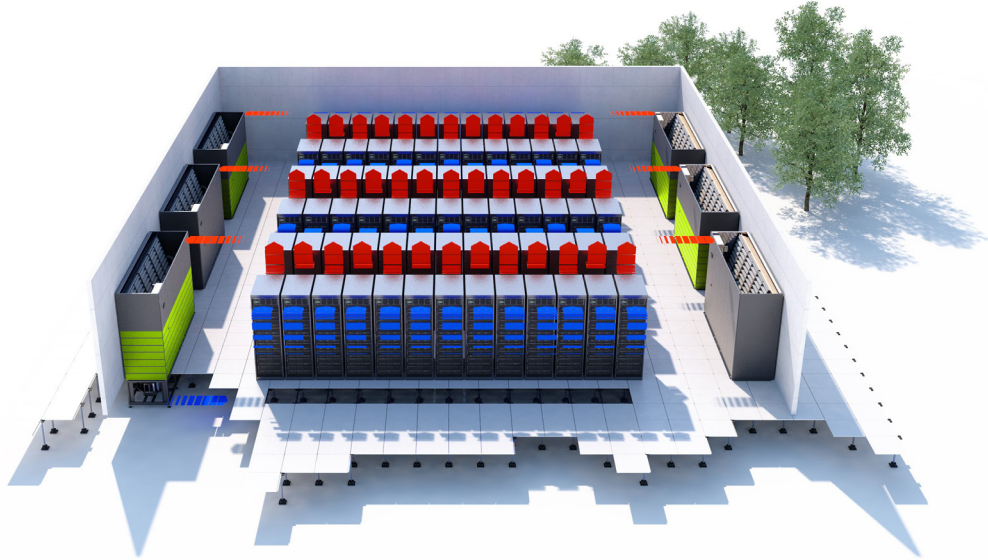

- **Distributed control** Units operate as if they were one big machine. Units share the values read by the probes and they operate according to the averages (max. or min. values) of all detected signals.

To address any localised hot spots, each single machine can be configured to automatically exit the network for a predefined time when peak loads need to be covered. As soon as the emergency condition has been solved, the units are networked again.

This solution is recommended with units having a cold source, a modulating fan and a thermal load close to the nominal value.

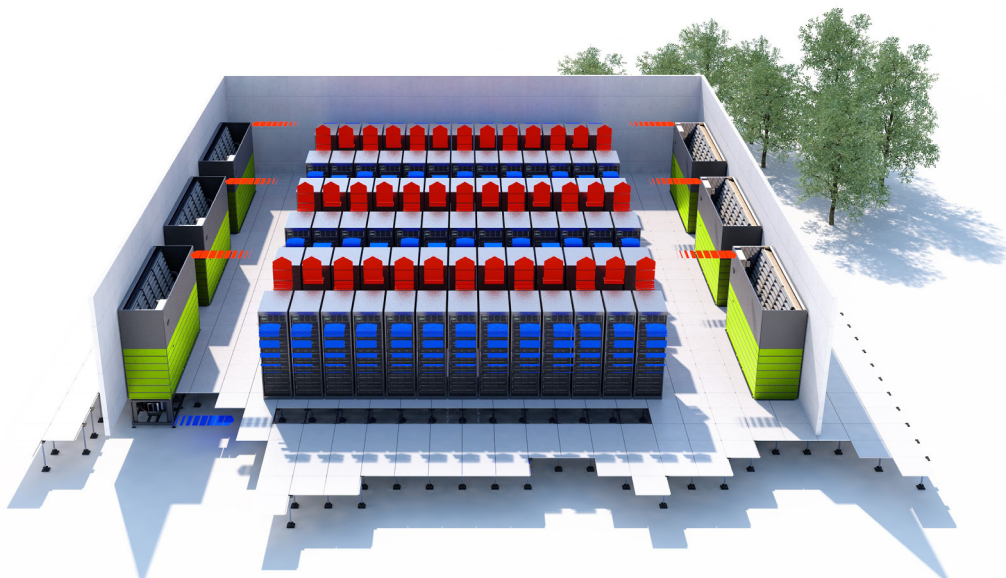

- **Dynamic and Continuous Optimisation** This function was developed to help the networked machines follow the load trends over time (both in terms of cold source and ventilation) in the most effective manner possible. Units share the readings of the probes and they are enabled one at a time as the demand grows.

In other words, as using the performance of the efficiency curves of components with brushless motors (e.g. EC fans) is the final target, the system does not wait until each unit is saturated before calling the next one; the second unit is indeed enabled as soon as the first one has achieved the threshold which represents the max. efficiency point. Active units operate as if they were one big unit.

With this solution, the number of machines always in operation within their max. efficiency area is the minimum required.

This solution is recommended with units having a cold source, a modulating fan and a variable thermal load over time.

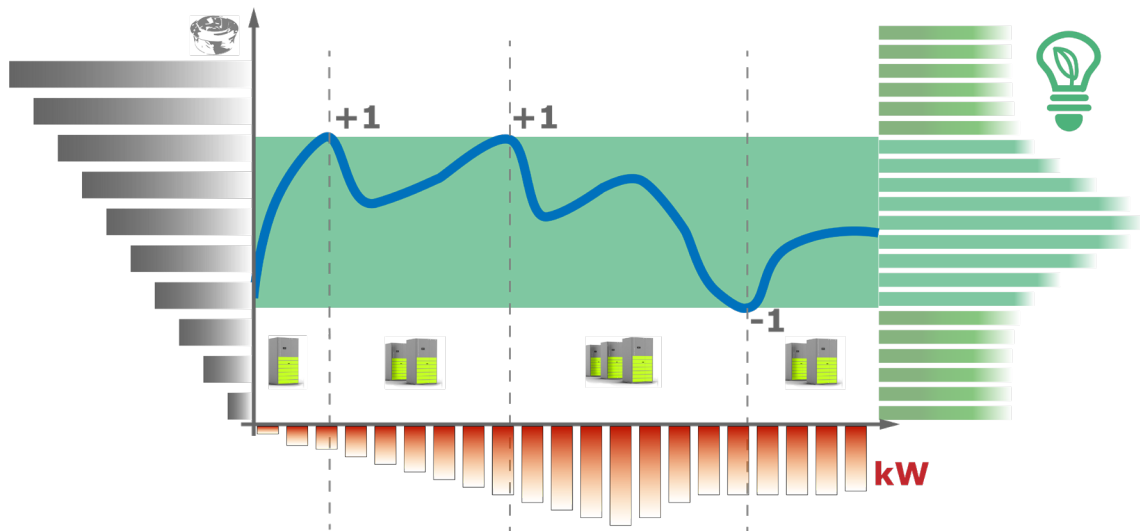

If the connection between the units fails, the units will individually work in "stand alone" mode.

Other accessories

VACO Stainless steel unit containment tank H=20mm

The containment tank is designed for placement under the base frame (option) of units that are installed in environments with raised flooring. The purpose of the tank is to collect and contain any leaking water from the unit, where applicable. We recommend that this option be installed together with the flooding sensor, to be fitted inside the tank.

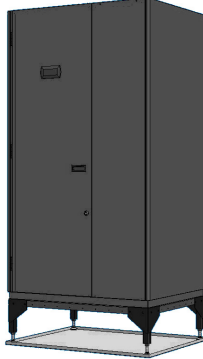

The containment tank is 20mm tall for all cabinets. Its dimensions change according to the table below.

Cabinet type		S	S-M	M	M-L	XL	XXL
Width	mm	1150	1400	1800	2200	2700	3350
Depth	mm	940	940	940	940	940	940

GABB Packaging in wooden crate

The units can be packaged in a HT wooden crate, in accordance with Directive ISPM15, suitable for export and ocean/container/air transport in addition to the standard packaging with profiles and stretch film.

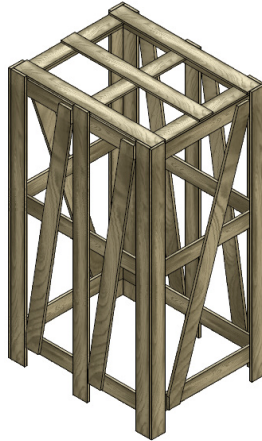

Moisture absorbing desiccant bags can be added to the units, upon request, to protect them against moisture during long distance ocean freight.

IPL Wooden crate packaging for return/delivery plenum

If the unit is packaged in a wooden cage and it is provided with a plenum as an option, the plenum must be placed in a dedicated wooden crate.

ISE Wooden crate packaging for Shutter module

If the unit is packaged in a wooden cage and it is provided with a motor-driven shutter as an option, this option must be placed in a dedicated wooden crate. The shutter module is shipped separately from the unit.

TECHNICAL SPECIFICATIONS

Datatech BTD PFW

Unit size		70	90	120	150	200	260	
Power mode	(1)							
Total refrigeration capacity		kW	69.5	89.4	118.6	150.7	198.2	263.2
Sensible cooling capacity		kW	55.8	72.3	95.9	118.8	158.5	208.0
SHR			0.80	0.81	0.81	0.79	0.80	0.79
NSEER			28.11	22.76	23.54	28.12	26.92	27.51
Air flow rate		m3/h	13000	17000	22500	27000	37000	47700
Absorbed power		kW	1.92	3.04	3.91	4.08	5.68	7.30
Max. available head		Pa	190	355	260	145	210	235
Total head loss in hydraulic circuit		kPa	77	85	73	124	120	157
Energy Saving mode	(2)							
Total refrigeration capacity		kW	48.7	63.6	90.5	105.0	151.0	187.0
Sensible cooling capacity		kW	48.7	63.6	90.5	104.0	151.0	186.0
SHR			1.00	1.00	1.00	0.99	1.00	0.99
NSEER			55.63	44.43	40.14	44.22	44.76	41.47
Air flow rate		m3/h	9500	12500	18000	21500	30000	39000
Absorbed power		kW	0.86	1.40	2.20	2.30	3.30	4.38
Max. available head		Pa	510	715	575	425	440	445
Total head loss in hydraulic circuit		kPa	39	44	43	51	72	82
Closed Aisle mode	(3)							
Total refrigeration capacity		kW	51.2	66.9	91.8	115.0	154.0	200.0
Sensible cooling capacity		kW	51.2	66.9	91.8	115.0	154.0	200.0
SHR			1.00	1.00	1.00	1.00	1.00	1.00
NSEER			39.96	32.45	30.66	34.94	34.00	34.71
Air flow rate		m3/h	11,000	14,500	20,000	24,500	33,500	43,000
Absorbed power		kW	1.25	2.00	2.90	3.20	4.40	5.60
Max. available head		Pa	395	575	450	285	335	355
Total head loss in hydraulic circuit		kPa	42	47	72	101	72	90
High Efficiency Coil (BAE)	(1)							
Total refrigeration capacity		kW	67.3	88.4	125.7	150.0	199.9	263.7
Sensible cooling capacity		kW	48.9	64.3	92.0	109.6	148.3	194.8
SHR			0.73	0.73	0.73	0.73	0.74	0.74
NSEER			40.19	33.57	31.62	34.86	33.49	33.18
Air flow rate		m3/h	9,500	12,500	18,000	21,500	30,000	39,000
Absorbed power		kW	1.19	1.86	2.82	3.06	4.30	5.70
Max. available head		Pa	415	490	395	325	320	325
Total head loss in hydraulic circuit		kPa	87	107	104	107	148	220
Fans								
Quantity		n°	1	2	2	2	3	4
Max. admissible air flow rate		m3/h	13,700	18,300	24,200	27,800	39,700	51,600
Absorbed power at max. air flow rate	(1)	kW	2.20	3.70	4.70	4.40	6.80	8.90
Max. available head at max. air flow rate	(1)	Pa	105	220	105	95	105	120
Max. air flow rate in high efficiency coil	(1)	m3/h	12500	17000	23500	26000	37000	48000
HYDRAULIC CIRCUIT								
Connectors		mm	87	107	104	107	148	220
Electric heater								
Capacity in standard version		kW	9	9	18	18	27	36
Capacity in oversize version		kW	13	13	26	26	39	54
Operating stages		n°	1	2	2	2	3	3
Humidifier								
Max. steam output		kg/h	8.0	8.0	15.0	15.0	15.0	15.0
Sound pressure level								
Sound pressure level	(4)	dB(A)	57	59	60	59	62	62
Sound power level	(5)	dB(A)	77	79	80	80	83	84
Sound power level	(6)	dB(A)	83	89	87	87	87	87
Dimensions and weights of basic unit								
Cabinet name			S	S-M	M	M-L	XL	XXL
Length		mm	1,100	1,350	1,750	2,150	2,650	3,300
Depth		mm	890	890	890	890	890	890
Height of air handling unit		mm	1,990	1,990	1,990	1,990	1,990	1,990
Height of fan section		mm	700	700	700	700	700	700
Net weight		kg	550	650	820	920	1,100	1,300

(1) Input air 24°C, 50% RH. Input/output water 7/12 °C, Available head at 20 Pa, Filters, ISO Coarse 75% (G4)

(2) Input air 28°C 40% RH. Input/output water 10/15 °C, Available head at 20 Pa, Filters, ISO Coarse 75% (G4)

(3) Input air 35°C 30% RH. Input/output water 18/23 °C, Available head at 20 Pa, Filters, ISO Coarse 75% (G4)

(4) Sound pressure level measure at a 2m distance in free field, as measured from the sound power level under ISO 3744 at nominal air flow rate

(5) Sound power level radiating from cabinet in underfloor or channelled air delivery conditions and channelled intake, at nominal air flow rate

(6) Sound power level emitted at the fan section delivery outlet, at nominal air flow rate

The specified cooling capacities are gross values. The net capacity is calculated by subtracting the power absorbed by the fan.

All data are referred to the open fan section mounted underneath a raised floor.

Datatech BTD PFW-DW

Unit size		70	90	120	150	200	260	
Power mode	(1)							
Total refrigeration capacity		kW	43.9	59.7	87.6	107.0	147.0	188.0
Sensible cooling capacity		kW	39.7	52.4	76.2	91.0	127.0	159.0
SHR			0.90	0.88	0.87	0.85	0.86	0.85
NSEER			20.60	18.80	18.30	22.30	20.10	21.00
Fans								
Quantity		n°	1	2	2	2	3	4
Max. admissible air flow rate		m3/h	11,340	14,580	21,060	24,300	34,830	42,930
Absorbed power at max. air flow rate	(1)	kW	1.8	2.6	3.9	3.9	6.0	7.2
Max. available head at max. air flow rate	(1)	Pa	245	460	280	200	200	255
HYDRAULIC CIRCUIT								
Total head loss		kPa	45	60	83	95	122	140
Connectors			1"1/4	1"1/2	1"1/2	2"	2"	2" 1/2
Electric heater								
Capacity in standard version		kW	9	9	18	18	27	36
Capacity in oversize version		kW	13	13	26	26	39	54
Operating stages		n°	1	2	2	2	3	3
Humidifier								
Max. steam output		kg/h	8.0	8.0	15.0	15.0	15.0	15.0
Sound pressure level								
Sound pressure level	(2)	dB(A)	53.1	54.9	58.0	56.2	60.2	59.7
Sound power level	(3)	dB(A)	73.6	75.4	78.5	77.2	81.2	81.2
Sound power level	(4)	dB(A)	79.7	85.4	85.5	84.4	85.0	85.0
Dimensions and weights of basic unit								
Cabinet name			S	S-M	M	M-L	XL	XXL
Length		mm	1,100	1,350	1,750	2,150	2,650	3,300
Depth		mm	890	890	890	890	890	890
Height of air handling unit		mm	1,990	1,990	1,990	1,990	1,990	1,990
Height of fan section		mm	700	700	700	700	700	700

(1) Input air 24°C, 50% RH. Input/output water 7/12 °C, Available head at 20 Pa, Filters, ISO Coarse 75% (G4)

(2) Sound pressure level measure at a 2m distance in free field, as measured from the sound power level under ISO 3744 at nominal air flow rate

(3) Sound power level radiating from cabinet in underfloor or channelled air delivery conditions and channelled intake, at nominal air flow rate

(4) Sound power level emitted at the fan section delivery outlet, at nominal air flow rate

The specified cooling capacities are gross values. The net capacity is calculated by subtracting the power absorbed by the fan.

All data are referred to the open fan section mounted underneath a raised floor.

TECHNICAL SPECIFICATIONS

Datatech BTD PFW

Unit size			70	90	120	150	200	260
Max. power absorbed by fans		kW	2.8	5.4	5.8	5.5	8.3	11.0
Max. power absorbed by standard heaters		kW	9.0	9.0	18.0	18.0	27.0	36.0
Max. power absorbed by oversize heaters		kW	13.0	13.0	26.0	26.0	39.0	54.0
Max. power absorbed by humidifier		kW	6.0	6.0	11.3	11.3	11.3	11.3
Max. current absorbed by fans	(1)	A	4.3	8.4	8.9	8.6	12.9	17.2
Max. current absorbed by standard heaters	(1)	A	13.0	13.0	26.0	26.0	39.0	52.0
Max. current absorbed by oversize heaters	(1)	A	18.8	18.8	37.5	37.5	56.3	77.9
Max. current absorbed by humidifier	(1)	A	8.7	8.7	16.2	16.2	16.2	16.2
Power supply	(2)	V/ph/Hz	400/3~/50 ±5%	400/3~/50 ±5%	400/3~/50 ±5%	400/3~/50 ±5%	400/3~/50 ±5%	400/3~/50 ±5%

(1) Current absorption at max. admissible operating conditions Refer to the specific wiring diagrams for the sizing of the power lines.

(2) The three-phase power supply MUST always include a neutral when the unit is supplied with a condensate exhaust pump and dual power supply with automatic switching.

Datatech BTD PFW-DW

Unit size			70	90	120	150	200	260
Max. power absorbed by fans		kW	2.8	5.4	5.8	5.5	8.3	11.0
Max. power absorbed by standard heaters		kW	9.0	9.0	18.0	18.0	27.0	36.0
Max. power absorbed by oversize heaters		kW	13.0	13.0	26.0	26.0	39.0	54.0
Max. power absorbed by humidifier		kW	6.0	6.0	11.3	11.3	11.3	11.3
Max. current absorbed by fans	(1)	A	4.3	8.4	8.9	8.6	12.9	17.2
Max. current absorbed by standard heaters	(1)	A	13.0	13.0	26.0	26.0	39.0	52.0
Max. current absorbed by oversize heaters	(1)	A	18.8	18.8	37.5	37.5	56.3	77.9
Max. current absorbed by humidifier	(1)	A	8.7	8.7	16.2	16.2	16.2	16.2
Power supply	(2)	V/ph/Hz	400/3~/50 ±5%	400/3~/50 ±5%	400/3~/50 ±5%	400/3~/50 ±5%	400/3~/50 ±5%	400/3~/50 ±5%

(1) Current absorption at max. admissible operating conditions Refer to the specific wiring diagrams for the sizing of the power lines.

(2) The three-phase power supply MUST always include a neutral when the unit is supplied with a condensate exhaust pump and dual power supply with automatic switching.

HYDRAULIC DIAGRAMS

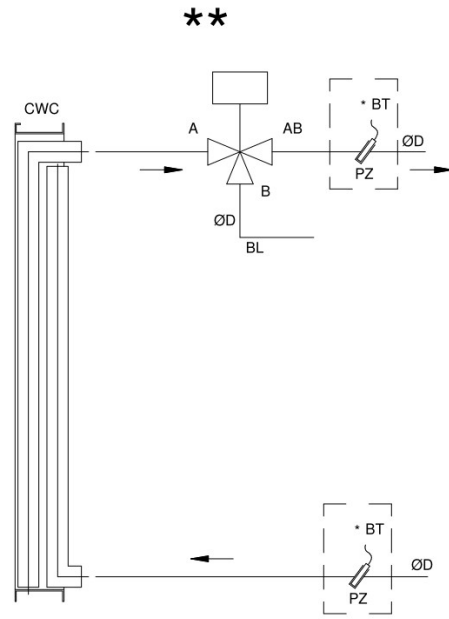
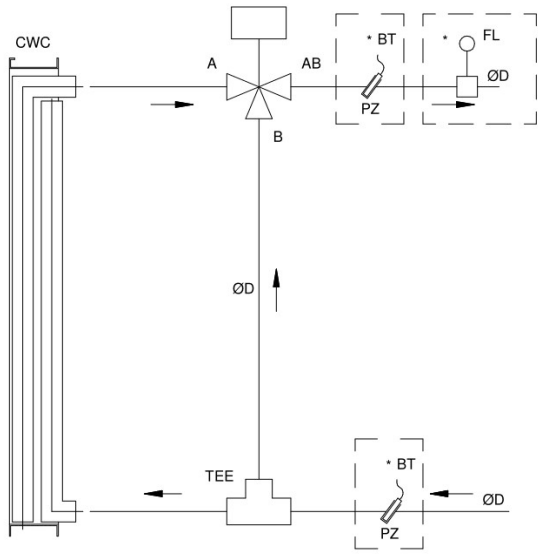

- *: Option
- ** : Version featuring 2-way valve (V2R) as option

Ref.	Component
BL	Bypass closing disc
BT	Water temperature sensor
CWC	Chilled water coil
FL	Flow switch
PZ	Sensor pocket

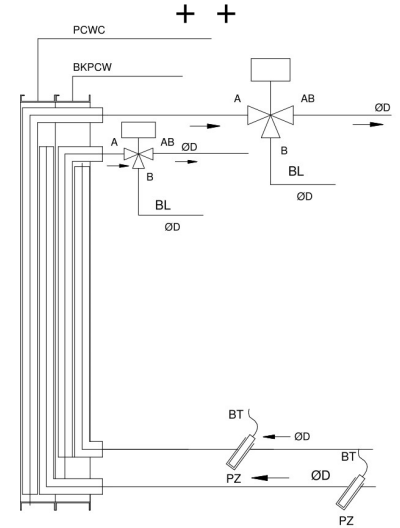
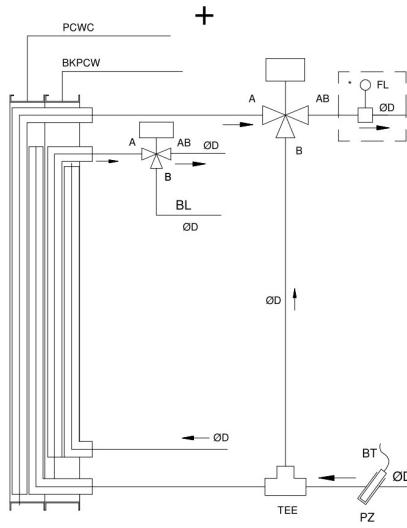
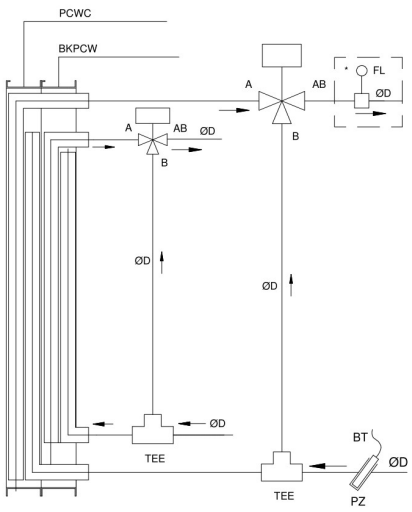

- *: Option featuring automatic coil switching (CAB)
- + : Version featuring 2-way valve (V2RS) as option on secondary circuit only
- ++ : Version featuring 2-way valve (V2R+-V2RS) as option on both circuits

Ref.	Component
BL	Bypass closing disc
BT	Water temperature sensor
BKPCW	Chilled water coil in secondary circuit
FL	Flow switch
PCWC	Chilled water coil in primary circuit
PZ	Sensor pocket

OPERATING LIMITS - DATATECH BTD CW-DW

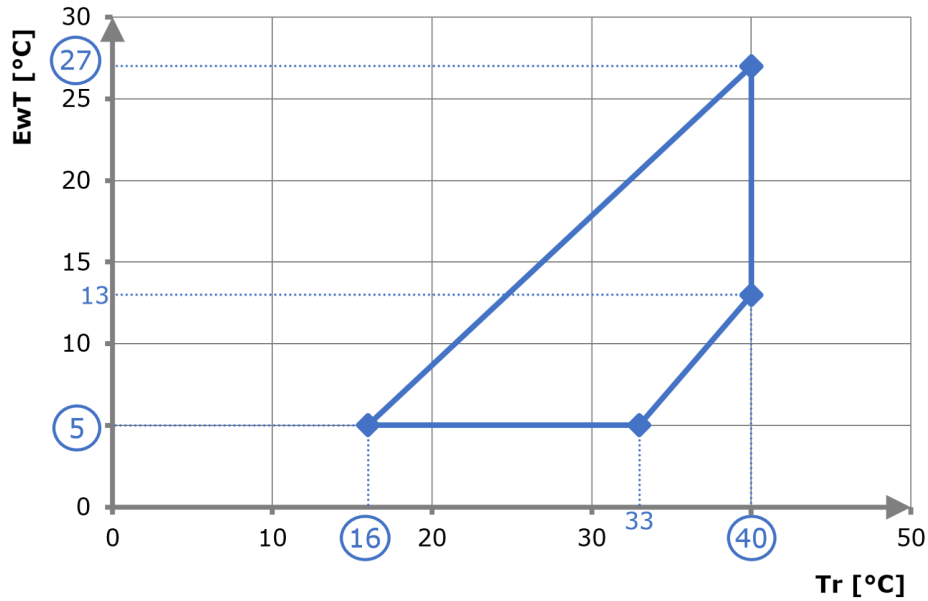

Tr: return air temperature to internal unit

EWT: Input water temperature

The limits above are general purpose: refer to the selection software to check whether the single units can be selected under specific conditions. Do not select units where the difference between the average water temperature and the ambient temperature exceeds 20°C or is below 8°C.

INTERNAL TEMPERATURE AND HUMIDITY RANGE

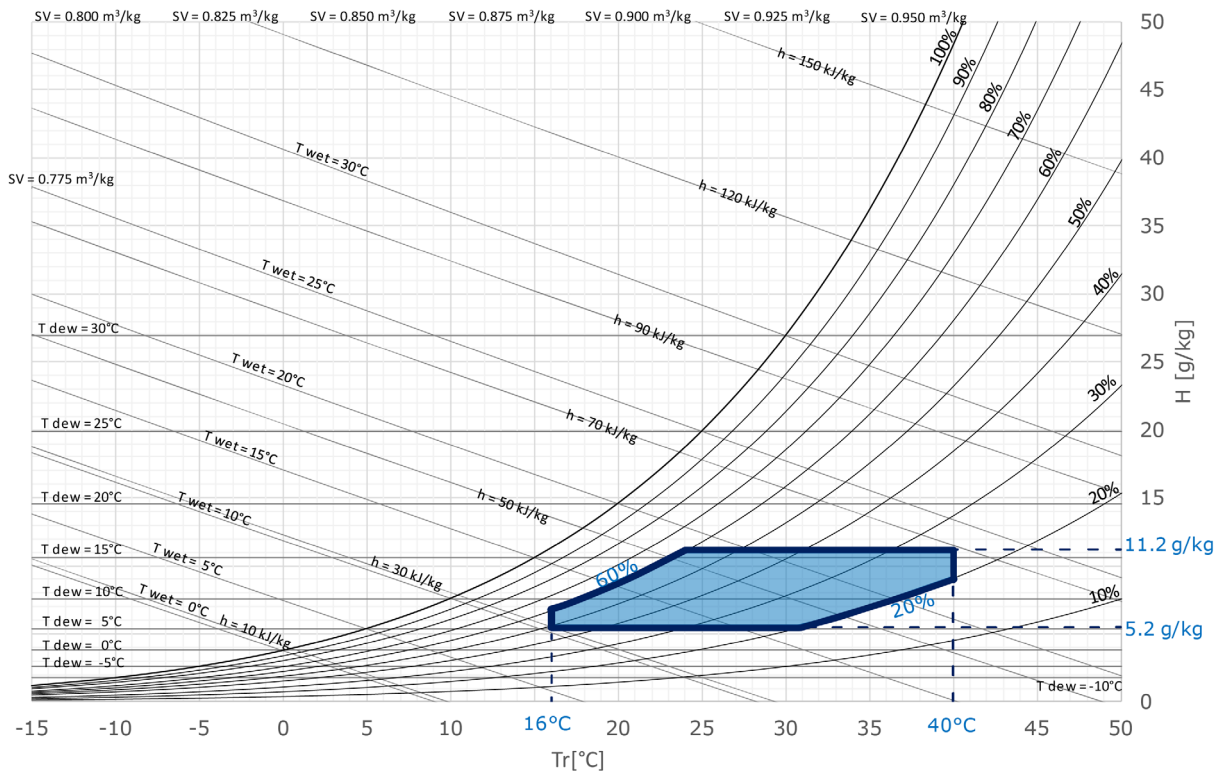

Limit values refer to the conditions of air return to the unit.

Indicative operating limits A check must at all times be made that the latent and sensible capacities meet the specific requirements of the application. Units may operate with larger limits as well, according to the global operating conditions.

The hydraulic circuits are PN10 (max. operating pressure equal to 10 bar). Upon request, units can be configured with hydraulic circuits having a higher max. pressure, either 16 or 25 bar specifically.

INSTALLATION TIPS

PUTTING IN PLACE

Check for possible obstructions in the finned coil intake line or in the fan delivery line.

Place the unit in a manner that assures the lowest environmental impact (noise emissions, integration with nearby structures, etc.).

Strictly comply with the clearance spaces indicated in the catalogue.

Datatech BTD units are designed and made for indoor use only. The hydraulic circuits are not provided with freeze protection.

ELECTRICAL CONNECTIONS

Always consult the attached wiring diagram, which provides all the instructions necessary for making the electrical connections.

Direct expansion units require energisation (close the power switch) at least 12 hours before start-up so that the heaters in the crankcase are powered.

Power to the heaters must not be cut out during short unit stops.

Before access is gained to internal unit components, engage the power switch to switch the power off.

The power supply line must be protected in accordance with current regulations.

Electrical connections required: three-pole power cable + earth, or three pole cable + neutral + earth; external interlock; remote alarm signalling.

HYDRAULIC AND REFRIGERANT CONNECTIONS

Make the refrigerant connections strictly following the instructions provided with the installation, operation and maintenance manual, in particular as regards the braze-welding, cleaning, vacuum and charging operations.

Engage the purge valves to carefully vent the hydraulic system, with the pumps switched off. This procedure is particularly important, as even small air bubbles may cause the evaporator to freeze.

Drain the hydraulic system during winter stops or use special anti-freeze solutions.

Install the hydraulic circuit with all the components shown in the referenced diagrams (expansion vessel, flow switch, storage tank, air valve, on-off valves, flexible connections, etc. Please refer to the user, installation and maintenance manual). If the flow switch is supplied separately from the units, connect it by carefully following the instructions provided with the units.

START-UP AND MAINTENANCE

Strictly follow the instructions given in the operation and maintenance manual. These operations must in any case be carried out by qualified persons.
